

RÖTTLER
THE CUTTING EDGE

F70A Series

Multi Purpose CNC Machining Center



Machining Equipment
Created for Performance
Racing & Engine
Remanufacturing.

So Advanced, It's Simple.

F79A MULTI PURPOSE CNC MACHINING CENTER

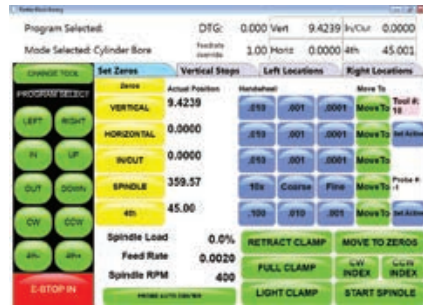

Windows Operating System

Rottler uses Windows Touch Screen Technology on a 15" (381mm) touch panel. The Windows software has many advantages such as it's common user interface and reduced learning curve.

Instant Internet Support

Rottler offers cutting edge internet support direct from your machine to the factory. Skype™ and a webcam are installed for video conferencing and internet support. This feature gives you instant, direct contact with Rottler right on the machine without even making a phone call. The standard webcam comes pre-installed so that Rottler technicians can see exactly what you are seeing. This saves a tremendous amount of time when trying to answer questions and allows the end user to maximize the capabilities and productivity of the machine. Shop busy or too noisy for talking? The pre-installed Skype™ application gives you instant messaging capabilities with Rottler technicians.

Workhead Box Way Slideway

Vertical machining requires rigid slideways for chatter free machining. Rottler exclusive spring loaded box way slideway design allows maximum rigidity and workhead tilt for back clearance during surfacing operations.

Traveling Column Design

Our proven Traveling Column Design features a stationary work piece for increased accuracy.

Extra Height Capacity

Easily handle medium size diesel blocks for increased versatility.

Large Turcite Coated Box Ways

Turcite coated bedways come standard for reduced friction, longer life and better accuracy.

Automatic Lubrication System

Provides years of trouble free use and reduced wear.

Extra Long T-Slot Work Table

Extra long work table offers enough space for dual workstations increasing productivity and versatility.

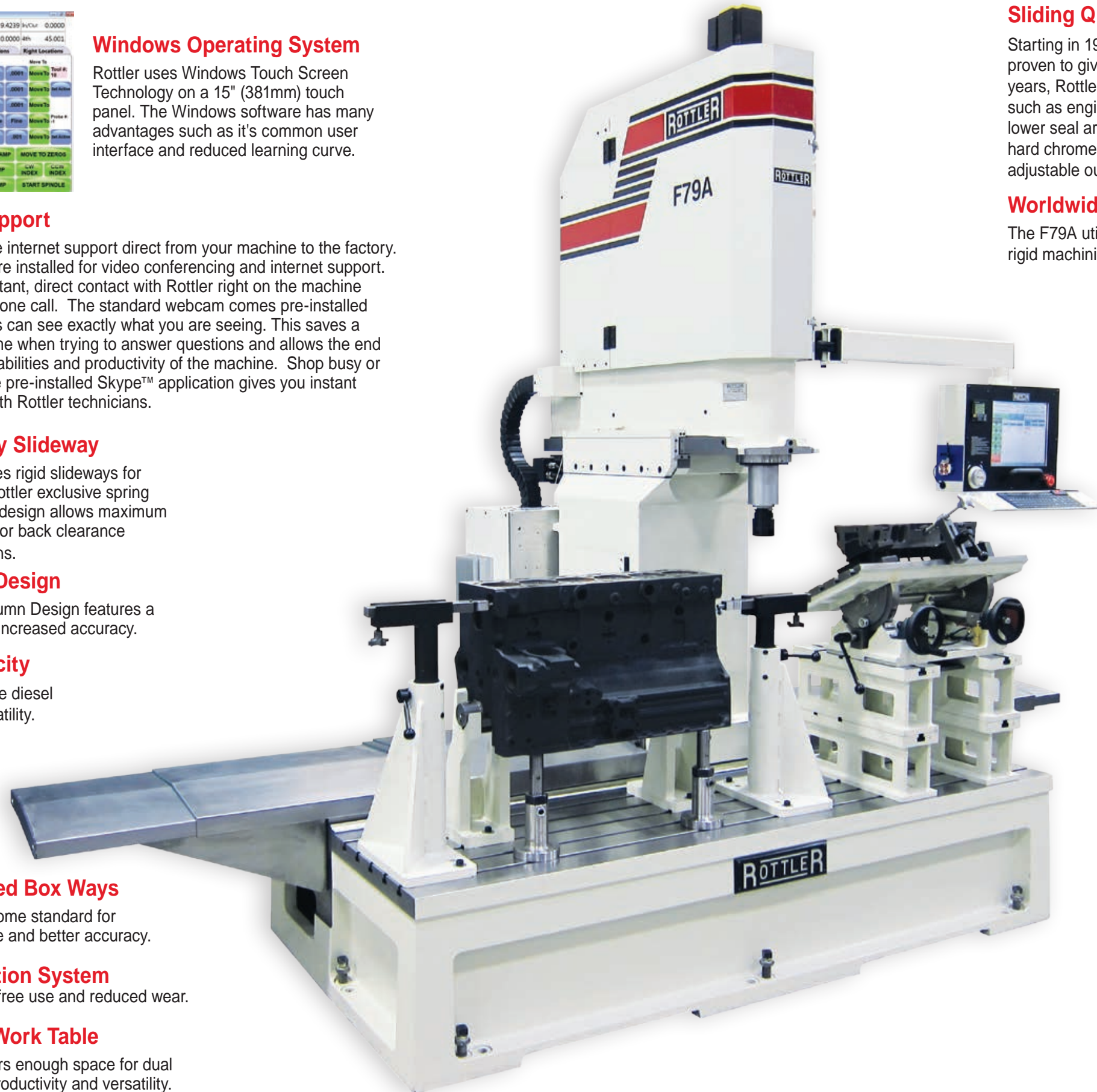

Sliding Quill Spindle Design

Starting in 1923 Rottler pioneered the sliding quill spindle design that has proven to give decades of precision and reliable machining. Over the last 90 years, Rottler has perfected this design which is ideal for deep hole machining such as engine block machining. Resleeving long cylinders and machining lower seal area are examples requiring this unique feature. The spindle is hard chromed and cross hatch external honed then mounted in precision adjustable outer support bearings.

Worldwide Standard CAT 40 Spindle Taper

The F79A utilize the Worldwide Standard CAT 40 taper for fast tool changing, rigid machining and worldwide versatility.

Optional Automatic Tool Changer

The F79A can accommodate an optional Automatic Tool Changing System for production machining applications.

Manual Hand Wheel

Offers the operator infinite control of machine movement in all axes for quick easy setup and adjusts variable feedrate when in automatic cycle.

Single Phase 208-240 V

The F70 models are power efficient and save electrical running costs.

Dual Workstations

The large capacity of the F79A allows dual work stations so two jobs can be set up at once. The photo above displays the first station showing Rottler's medium in-line block set up for boring and surfacing on universal small to medium in-line and V block fixture. The second station shows a cylinder head set up on Rottlers leveling table for surfacing head gasket fire deck.

Automated Workhead Tilting System

For surfacing operations, the spring loaded workhead automatically tilts so that there is no back cut while the surfacing cutterhead passes over the machined surface.

AC Brushless Servo Motors with BISS Encoders

The F79A has the latest technology AC servo motors with BISS encoders offering 100 times finer resolution compared to previous models. These new AC servo motors give maximum torque and performance throughout the RPM range for improved accuracy and increased productivity.

Direct Drive Precision Ball Screws

Give long trouble free life and accurate movement. Backlash problems relating to belts or gearboxes are eliminated.

OVERVIEW

The F70 Series machines are designed for both the small to medium size diesel engine rebuilder as well as the performance racing engine builder.

Since 1923, Rottler has been designing and manufacturing machines and we have used this experience and knowledge to design a new class of machine. The F79A Model completes our current line of Rottler machining centers.



Time is money - 75% time saving over manual machines

Diesel Engine Remanufacturer

The **small to medium size diesel engine remanufacturer** requires an automatic machine that is easy to learn and fast to operate so any block can be machined quickly and accurately. In order for engine rebuilders to move out of the manual machine age and into the CNC era, they need computer technology. Features such as Rottler's Windows Touch Screen Control Panel combined with Conversational Programming allow virtually anyone to easily operate these machines.

Performance Engine Builder

The **performance racing engine builder** requires a versatile multi purpose machining center that can handle a wide variety of engine machine work. From simple jobs like boring a block and surfacing a head to complex machine work like line boring and general CNC machine work and making parts.

VERSATILITY



Automatic 4th Axis Block Roll Over Fixture

Rottler's Universal Quick Load/Unload Automatic 4th Axis Block Roll Over Fixture and Software allows the computer to rotate the block or cylinder head during the automatic machining cycle. Large V blocks can be rotated 360 degrees to allow special machining jobs such as stroker clearancing in the same set up as boring, surfacing and lifter bore machining. The tail stock is pneumatically operated allowing easy and fast loading and unloading of heavy blocks.

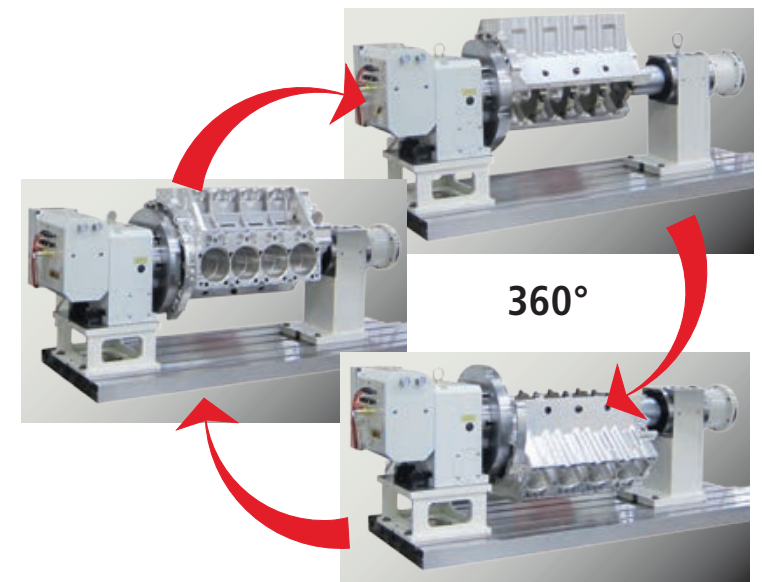

Automatic Tool Changer – ATC

The ATC allows the F79A to change tools automatically without operator involvement. Once the block has been loaded in the 4th axis, the machine works automatically unattended. The probe is selected from the ATC then probes the head gasket decks and the 4th axis levels the block then the probe measures the centers of each bore, then changes the tool and bores all cylinders, changes tool and surfaces both decks and then the block is ready for unloading.

Common, everyday jobs such as boring, surfacing and line boring can be easily automated with the F79A machines. Operator attendance is only required for set up. The machine is capable of boring along a complete cylinder bank automatically. Likewise, the machine is capable of line boring along a main line automatically.

Automatic Boring Cycles

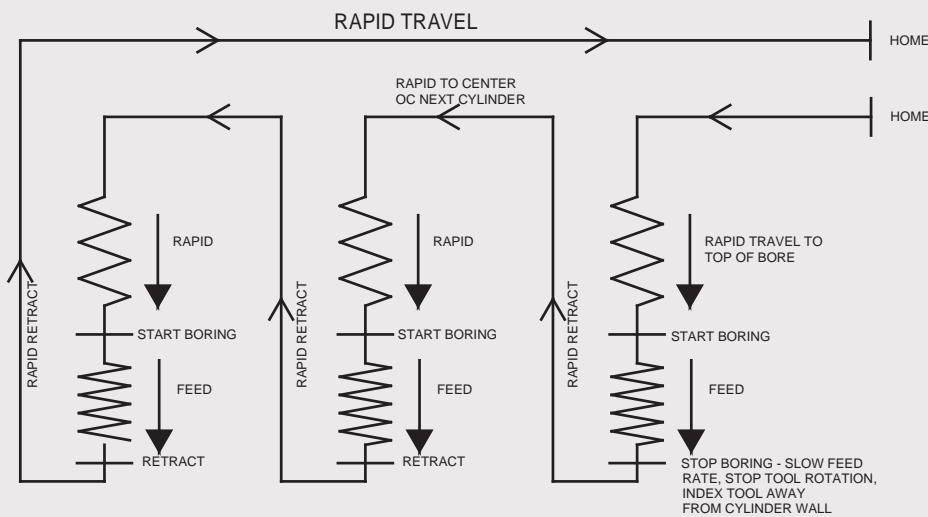

Pioneers in Automation

Over 20 years ago, Rottler pioneered automation by utilizing electronics and computers. Today, Rottler uses the latest computer technology to make automation easy to learn, versatile to operate and upgradeable for future software. Windows Operating Systems and touch screen controls make a simple operator interface. Touch screen control allows only the buttons and information required for each operation to be displayed, 'hiding' the complex computer functions in the background. Operators are able to learn complex and advanced machining functions in just a few days.

Productivity

Jobs can be completed in a third of the time of conventional machines. While operators perform other job functions, the F70A completes automatic cycles unattended.

Surfacing

Often when surfacing a block, more than one pass is required. The F79A can be programmed for multiple passes, moving down the exact amount each pass and completing with a finish cut for the required surface finish during the final pass.

Bore centers are either measured from the block or from a blueprint, then saved in the memory. The F79A machine moves automatically to the exact positions, which is useful when multiple boring operations are required for jobs such as resleeving. For special applications, optional Renishaw Wireless Probing can automatically find bore centers and measure diameters.

Resleeving

When resleeving the lower seal area of wet liner blocks, it is often required to bore a diameter larger than the upper diameter. Rottler's Automatic Lower Sleeve Repair Software allows the machine to offset so that the boring tool will clear the upper diameter, move down, then move back on center to bore the lower area on center with the upper bore. Once boring is complete, the machine will index the cutting tool, offset the programmed amount and retract and continue to the next cylinder automatically.

Automatic Lower Sleeve Repair Software

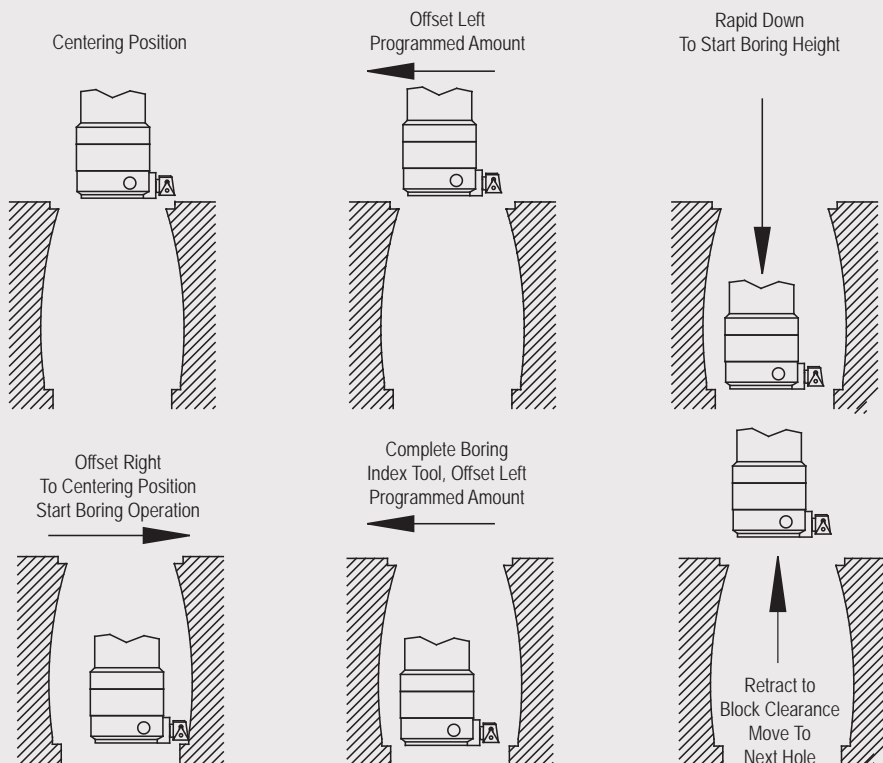

Rottler has combined in house CNC programming and machining experience with software and programming experts to develop a new conversational programming system that is easy to learn and operate. The use of Windows style icons and graphical displays makes programs easier to understand. The old fashioned abstract G&M code programming has been replaced with easy to understand conversational icons and menus.

The use of Windows information allows easy handling. Everyone knows about file saving and copying to external laptops and desktop computers. Programs can be emailed worldwide via the Internet and transferred by simple USB flash memory drives.

ROTTLER CAD/CAM

(Computer Aided Design and Manufacturing)

While the operator is developing a program on the machine, laptop or desktop, the software is calculating things like tool paths in the background. Our software is able to convert a drawing into a complex CNC program and run the machine with very little operator involvement.

Circular Interpolation Single Point Counterbore Tool

Combined with Rottler's unique software, counterbores and thrust faces can be finished with a single point machining method resulting in perfectly flat surfaces and fine surface finish. Special software and cutting inserts allow vertical undercuts to increase the corner radius to suit OEM requirements.

Water Hole Repairs

Large engine blocks and castings require many different repair and machining processes. The full three axis CNC control of the F79A series gives the machine the capability to perform custom programs to be written on the touch screen and saved in the memory for future use. For example, CAT3400 blocks have water holes in the head gasket face and often rust/corrode as a result of acidic water which requires them to be milled out, the plugs fitted and the head gasket face to be surfaced. The F79A allows a simple CNC program to be written and these holes to be machined out in one automatic cycle. Plugs can then be fitted and the block surfaced. This can be done while the block is set up for boring and surfacing work, saving hours of time and improving accuracy.

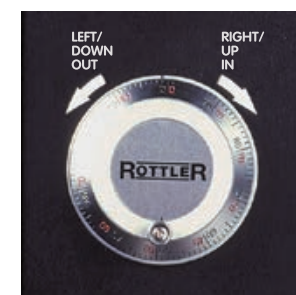

Handwheel for Manual Movement and Variable Feedrate

The electronic handwheel of the F79A machines has many uses. For manual movement, the operator is able to move the machine by rotating the handwheel just like a manual machine. The handwheel has a clicking action and each click moves the machine an exact amount: In 'Coarse Mode' the machine moves .010" (0.25mm) per click allowing very fast movement. In 'Medium Mode' the machine moves .001" (0.025mm) per click allowing slower movement. In 'Fine Mode' the machine moves .0001" (0.002mm) per click allowing very fine movement of the machine.

Once the machine is operating in automatic cycle, the operator is able to vary the feedrate or speed of movement from zero to 100%. This allows operators to slow down and speed up automatic movement while not changing the spindle/cutting speed. This function is ideal for operators learning the machine and checking their programs to be sure they have best productivity and safety, and not damaging cutting tools and jobs.

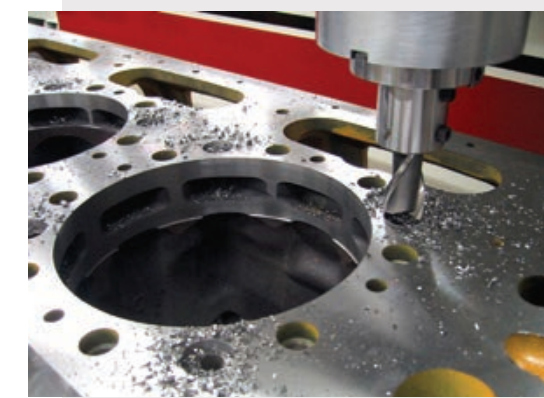
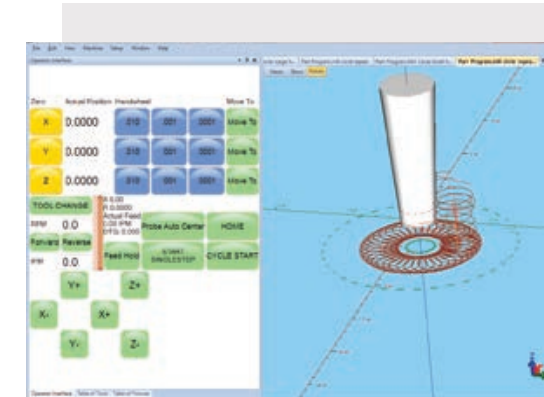

ROTTLER EXCLUSIVE TOUCH SCREEN PROGRAMMING

Control Summary

The conveniently located control pendent centralizes the machine controls. Only the buttons and interactive menus required for a particular machine operation are displayed. Machine operations can easily be done manually or automatically, with the ability to store programs in memory. Digital readout allows the operator to accurately monitor position at all times. Control operates in metric and inch systems.

Fully Programmable Cycles

Conversational three axis CNC control, PC based with Windows Operating System.

Dimensions and Control through Touch Screen:

- Program Bore Centers, Exact Depth, Speed, Feed, etc.
- Machines complete bank or main line in Automatic Cycle.
- Lower Offset Boring allows lower sleeve repair in Automatic Cycle.
- Circular Interpolate Counterbores for Radius Undercut or Wide Counterbores.
- Surfacing/Milling – Multiple Pass – program for Rough Cut and Finish Cut for superior surface finish.
- Line Boring – program the bearing bores and length of each bore and the machine automatically moves from bore to bore, completing the line unattended.
- Face Main Line Thrust Faces square to centerline of Crankshaft using Rottler Circular Interpolation software.

Features

Automatic

Programmable

PC Control/Windows

Versatile and Flexible

Variable Speeds & Feeds

AC Servo Motors

Power Drawbar

Hardened Boxway Bed

Turcite Coated Bedways

Precision Ball Screws

T-Slot Table

Benefits

Moves accurately from bore to bore unattended.

Saves all settings in memory for future use.

Can be easily updated for additional functions.

Bore, surface, line bore, ream, drill, tap, etc.

Allows surface finishes as low as 10Ra.

Maximum torque and performance at all speeds.

Quick, easy tool changing at the press of a button.

Ensures exceptional rigidity for accurate machining.

Reduced friction for smooth movement and long life.

Precision ball screws give accurate positioning.

Clamp any fixture and job quickly and easily.

Centering - 3 methods



1. Blueprint

Enter centers of bores from blueprint drawing into touch screen and the machine will bore to exact blueprint dimensions.

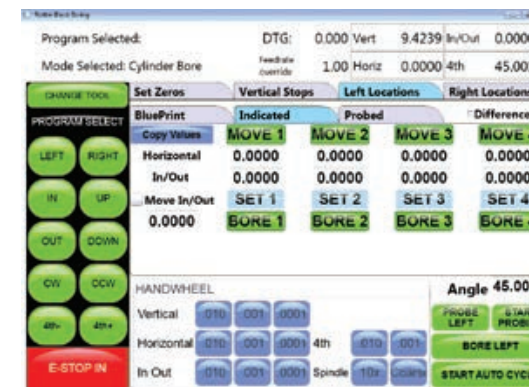

2. Indicate

Center Cutterhead in bore using digital or dial gage then touch 'Set button' and the machine memorizes the bore center.



3. Probe

Machine will automatically probe all bores and memorize dimensions of centers and measures bore diameters.

After centering is completed, touch 'Auto Cycle' and the machine will automatically bore to the exact dimensions. These dimensions are saved under a block name for future use.

Versatility & Simplicity



Main & Cam Line Bore

Enter distance to each bore and length of each bore and the machine automatically bores the complete line.



Thrust Cutting Main Line

Allows operator to easily program for thrust cutting using circular interpolation. Both sides of thrust can be machined in one automatic cycle.



Connecting Rod

Combined with Rottler Connecting Rod Fixtures, allows both big end and small end to be bored in one set up ensuring perfect parallelism and center to center distance.



Mode Screen

Allows operator to select operation to preform. Information is saved in the computers memory.

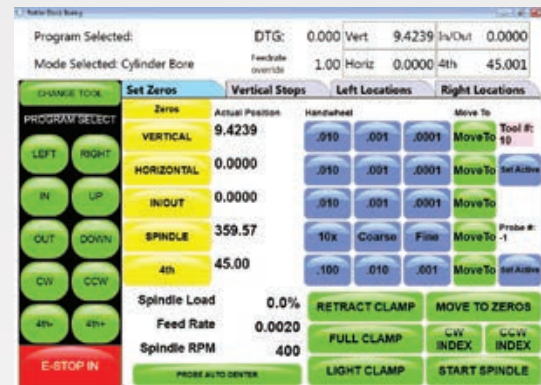

Set Zeroes

Simply set zeroes to begin the set up of the job and start automatic cycle.



Vertical Stops

Enter length of bore, sleeve, counterbore, etc and the machine will bore to the exact depth. Lower Sleeve Repair allows a lower diameter that is larger than an upper diameter to be bored in one automatic cycle.

SET UP AND MEASURING INSTRUMENTS

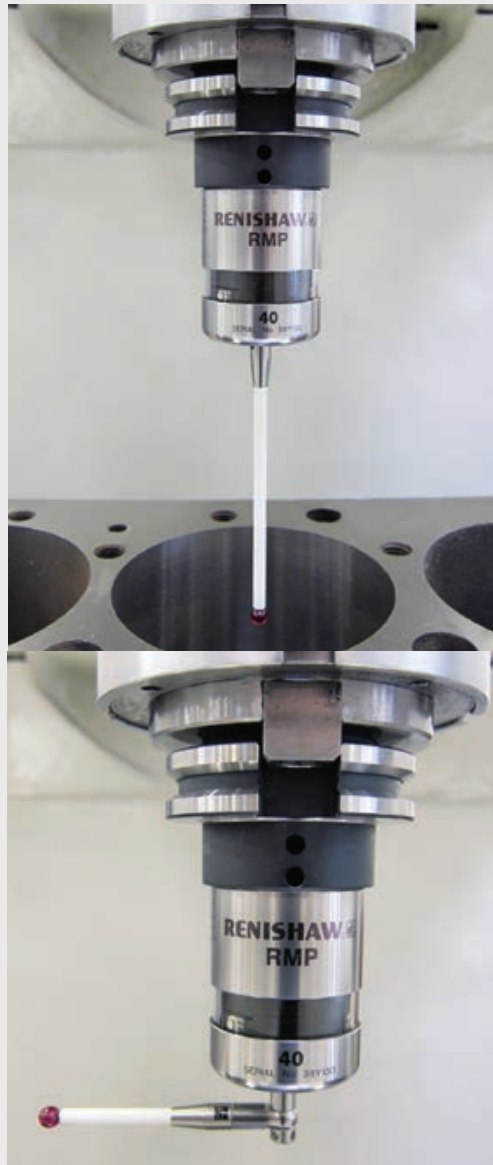

Rottler has a wide selection of micrometers, probes, indicators, setting fixtures and magnetic holders to allow versatile and accurate size setting for all machining requirements.

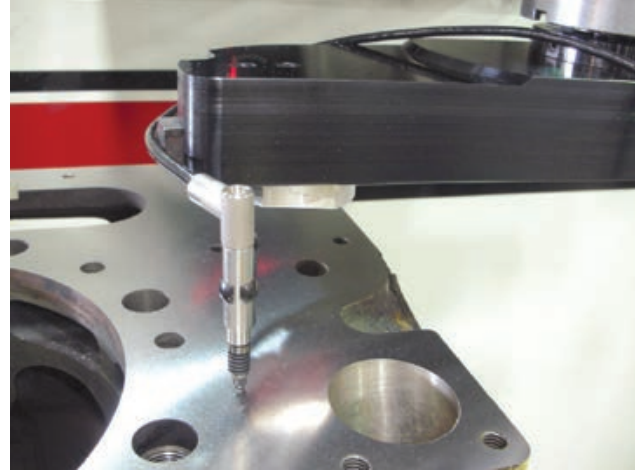

Digital Run Out Probe and Readout

The digital run out probe allows leveling and precise centering with digital readout on the control panel. Check level and alignment of decks, center in cylinder bores and main lines, etc.

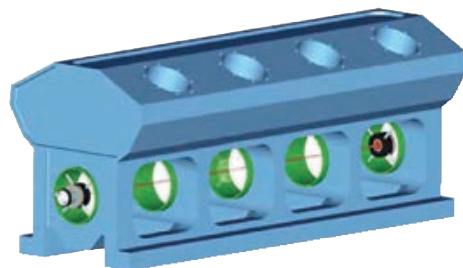
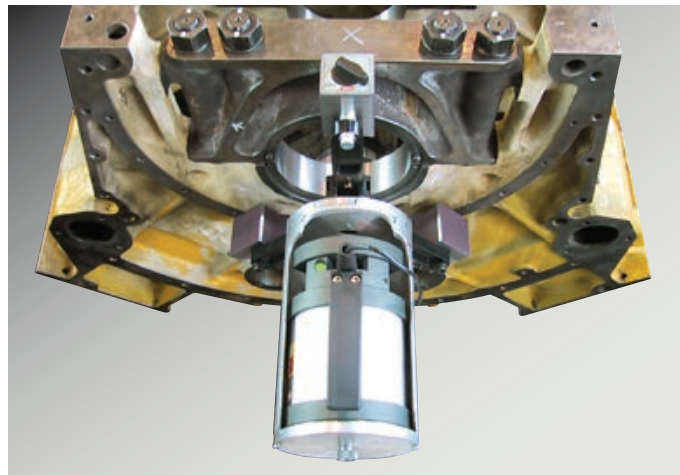

Laser Alignment

Engine Block Laser Alignment has provided engine machinists with a fast, reliable method of measuring a line bore for straightness. The laser system has proven to decrease inspection times significantly and virtually eliminated dedicated, expensive gauging. Computer printed results are available for future reference.

Wireless Radio Probing

Computer controlled wireless probe automatically finds cylinder bore centers and at the same time measures bore diameters. The difference between the drawing blueprint and the probed dimensions can be displayed by touching one button.

The deck (head gasket face) can be probed to check flatness and squareness to ensure accuracy and minimum metal removal when surfacing.

Upper and Lower Centering

With the use of a radio probe, the upper and lower bores of wet liner blocks can be probed to check concentricity and perpendicularity to ensure that the block is set up correctly before machining.

TOOLING & CUTTERHEADS



Spindle Adapters

The CAT40 worldwide standard Spindle Taper allows a wide selection of spindle adapters which allows the use of a wide variety of industrial tooling. ISO 40, R8, Morse Taper #5 and 1" (25.4mm) are available. Rottler also has a blank spindle adapter to allow customers to machine and adapt special requirements.

Milling Cutter Holders

Collet Chuck Kits with CAT40 taper allow milling tools such as end mills, slot drills and reamers to be used.

Flycutters and Milling Heads

Surfacing with the F79A machine can be done during the same set up as boring. 10" (250mm) and 14" (360mm) flycutters can be used with CBN inserts for high speed dry surfacing giving excellent surface finish results. The deck of a large block such as a V12 can be surfaced in less than 10 minutes. Multi Teeth Milling Heads can be used for milling welded and spray built up surfaces. Small diameter milling heads are ideal for facing main bearing housing contact surfaces in preparation for line boring to standard diameter. Special Surfacing Software allows very wide surfaces up to about 26" (660mm) to be surfaced.



Boring Cutterheads

Rottler manufactures a complete range of CAT40 quick change boring cutterheads for boring and sleeving operations from .750" (19mm) to 7" (178mm). The air assisted CAT40 quick change retention system minimizes down time between tooling changes. Cutterheads can be changed in seconds!

CUTTING INSERTS

Rottler's tag line is 'The Cutting Edge', and we take pride in offering many different grades of cutting inserts for dry, high speed cutting a wide variety of materials. Decades of experience machining engines worldwide allows Rottler machines to dry cut a wide variety of parts. **CBN inserts** give exceptional long life for surfacing gasket faces as well as produce fine surface finishes for reliable sealing of metal gaskets. Dry CBN surfacing eliminates the need for wet grinding and at the same time gives flatter surfaces as cutting pressure is substantially reduced compared to surface grinding. **PCD inserts** allow soft metals such as Aluminum to be surfaced at high speed without coolant.

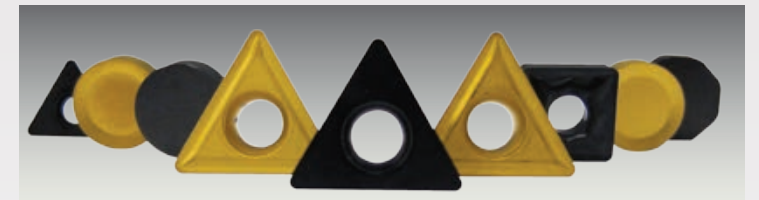

Rottler offers several different grades of **indexable carbide inserts** for cylinder boring & sleeving and main & cam line boring. **Special Black coated carbide inserts** are capable of standard to heavy sleeve cuts up to 1000rpm. **Triangle inserts** work well where cutting a bore to a square shoulder is needed, such as sleeves and counterbores. **Finishing Inserts** provide a sharper edge which results in a smoother surface finish on the cutting surface, ideal for finishing counterbores. **Carbide inserts** are available with 1/64" (0.4mm) and 1/32" (0.8mm) corner radius. Specially custom available for operations such as chamfering, O-ring grooving, undercutting and blind hole boring.



Octagonal Cutting Inserts

New Octagonal 16 Cutting Corner Surfacing Inserts have increased corner radius to allow faster feed rates and finer surface finish.

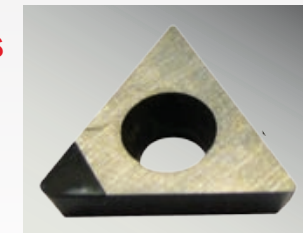

PCD Tipped Insert for Boring Aluminum

PCD cutting corner allows aluminum to be bored at high speed without any coolant.

LINE BORING

Over 20 years ago, Rottler pioneered right angle drive line boring and today are world leaders in this field. Rottler has developed a wide variety of tooling and fixtures so that blocks and heads can be easily and quickly set up and machined fast, automatically and accurately. Programming is simple and variable feedrate controlled by the handwheel during automatic cycles allow operators to easily learn to program and operate these machines without accidents and down time.

Bar Sag Error associated with horizontal bar type machines is totally eliminated. Machining lines is considerably faster and size control is consistently within a fine tolerance. Thrust facing using Rottler circular interpolation software can be done in the same set up ensuring perfect squareness with bearing centerline.

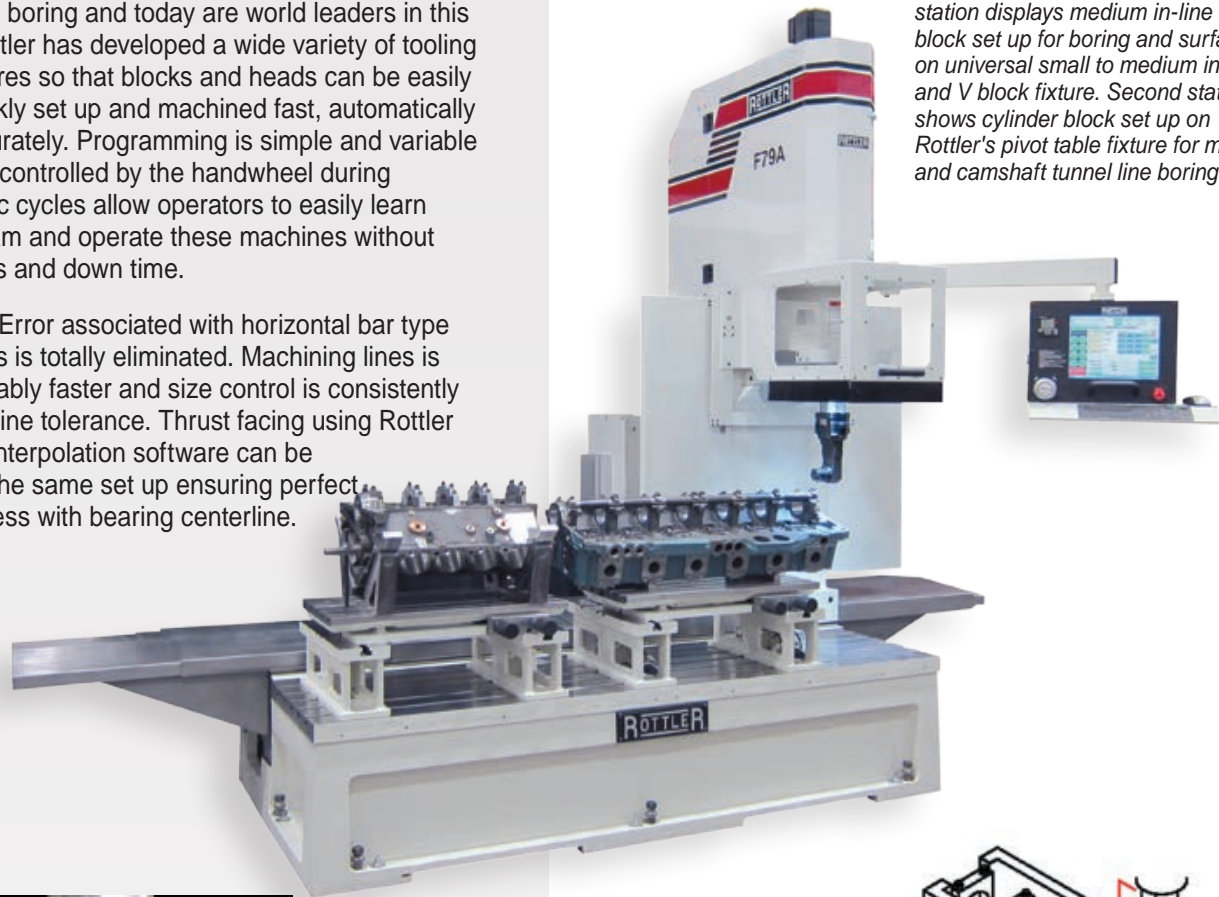

F79A with Dual Workstations. First station displays medium in-line block set up for boring and surfacing on universal small to medium in-line and V block fixture. Second station shows cylinder block set up on Rottler's pivot table fixture for main and camshaft tunnel line boring.

Rottler's unique right angle drives machine each bore individually and the digital display ensures perfect accuracy and alignment.

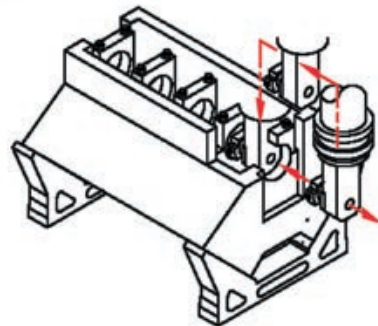

Special steel main bearing housings found in high power diesel engines such as MTU 2000 require high speed machining to obtain superior accuracy of roundness, straightness, parallelism and surface finish.



The F79A series are able to machine main bearing cap registers in the block to ensure they are perfectly flat for maximum contact with main bearing caps. At the same time, the diameter is reduced for line boring back to standard diameter.

LINE BORING EQUIPMENT

Line Bore Tooling

Rottler's Unique Right Angle Drive Line Boring Attachments allow for accurate machining of bearing lines from small cylinder heads such as CAT3406 and Detroit 50/60 Series up to large blocks such as CAT C27 and CAT3412. Special cutterheads with micro adjust tools are available from Rottler's engineering department. Repairs such as sleeving and cutting spray weld can be done. Operators prefer this system as there is no bar in their way when measuring and boring/repairing bearing housings. Special steel main bearing housings found in high power diesel engines such as MTU 2000 require high speed machining to obtain superior accuracy of roundness, straightness, parallelism and surface finish.

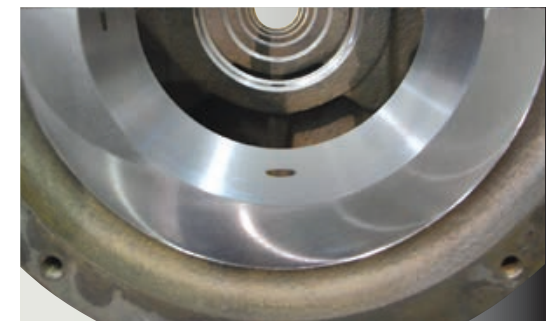
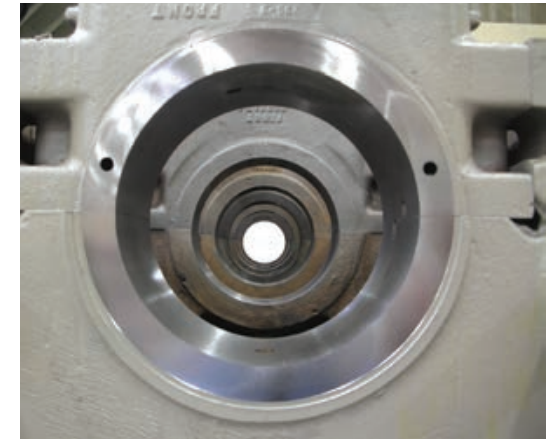

Right Angle Drive

The Belt Drive Right Angle Drive is very slim to allow line boring of small blocks where there is reduced clearance between bearing housings.



Line Bore Fixtures

Rottler offer fast set up and versatile line boring fixtures. Small blocks and cylinder heads can be set up very quickly on the Rottler Line Bore Pivot Table. T slots allow versatile clamping and V cradles allow V blocks to locate accurately for minimum set up time. For mid range size blocks, Rottler's 2 piece Adjustable Parallel Line Bore Fixture allows mid range diesel blocks to be set up and adjusted for main and camshaft line boring and machining main cap registers (the surface in the block where the main caps contact the block). 4 bolt conversions and drilling and tapping are all able to be done in the same set up.

Thrust Facing

Rottler's unique circular interpolation software and thrust facing tooling allow thrust faces to be machined perfectly square to bearing centerline using the same right angle drive that is used for line boring. Single point cutting allows build up to be removed without chatter resulting in fine surface finish.

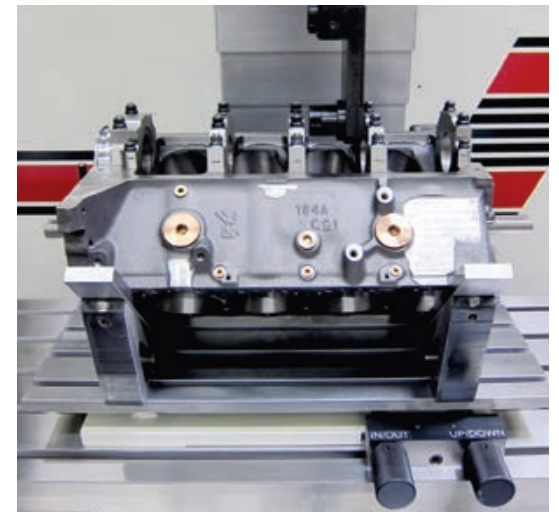

Line Bore Pivot Table

Rottler's Line Bore Pivot Table allows small blocks and cylinder heads to be set up and adjusted for line boring. The T-Slot Table allows versatile clamping of a wide variety of jobs.

CONNECTING ROD MACHINING

STANDARD EQUIPMENT

Touch Screen Software

Easy to learn and fast to operate.

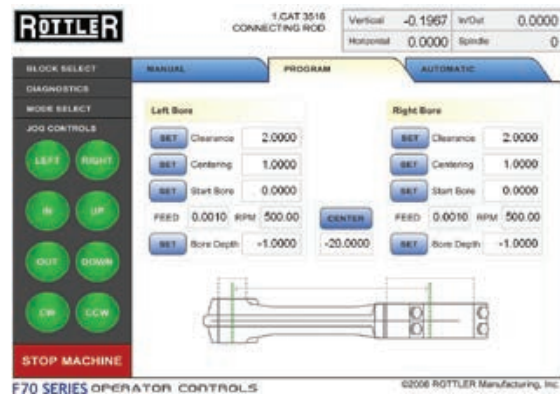

Special double diameter cutterheads allow both the big end and small end to be bored in one automatic cycle. These cutterheads have pre-settable cartridges and can be adjusted in .0002" (.005mm).

Connecting Rod Fixtures

Rottler's patented Connecting Rod Fixtures allow large connecting rods to be surfaced and bored on the F79A machines.

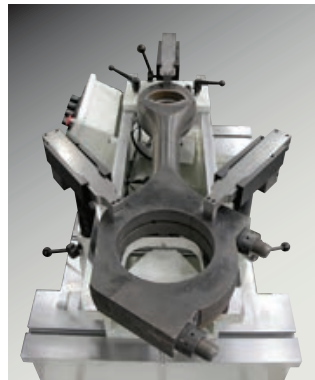

The Rottler boring fixtures allow both big end and small end to be bored in one set up resulting in perfect parallelism between big end and small end. All the rods in a set can be accurately bored for equal center to center distance, a must for today's high compression diesel engines. Special heavy duty fixtures available for boring very large, heavy connecting rods found in natural gas compressors and workboat marine engines.



Leveling Table

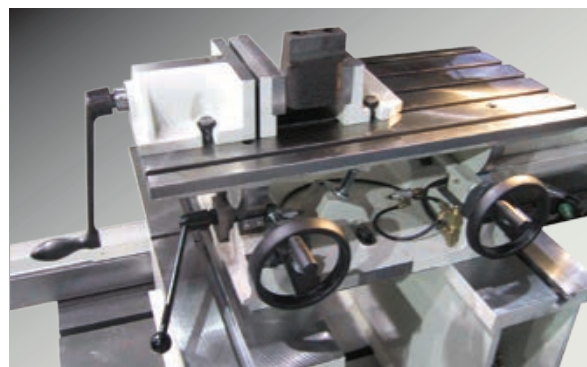

Rottler's Dual Axis Leveling Table with two piece vice used for surfacing Connecting Rod Caps and Main Bearing Housings in preparation for main line boring.

Surfacing Fixture

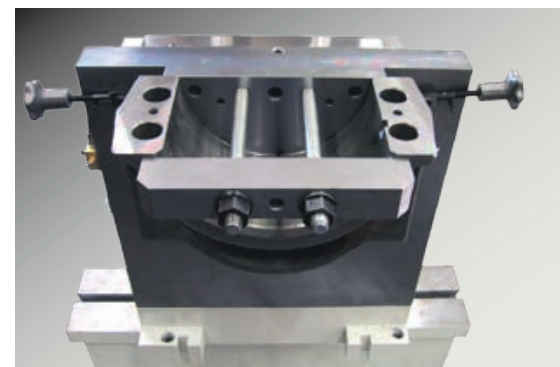

Heavy Duty surfacing fixture to prepare Natural Gas Compressor Rods for boring. The parting surface must be through the centerline of the bore.

- CNC (Computer Numerical Control) Machine using Windows Operating System and Industrial PC with Intel Processor. Precision Programming and Control through a 15" (381mm) Computerized Touch Screen.
- Software options available for Programmable & Automated Cycles such as Boring, Surfacing, Lower Sleeve Offset Boring, Water Hole Repairs, Main & Cam Line Boring, General CNC Machine Work
- USB flash drive for file transfer to and from computer
- Internet connection to the machine computer must be provided for training support and service.
- Machine/Computer can operate in either inch or metric system
- Three Axis movement by Direct Drive Precision Ball Screws
- All motors - AC Servo Motors with BISS Encoders - Infinitely Variable
- Horizontal Movement (X Axis) - Left and Right Direction - 72" (1830mm)
- Horizontal Movement (Y Axis) - In and Out Direction - 14" (355mm)
- Vertical Movement (Z Axis) - Up and Down - 18" (457mm)
- Vertical, Horizontal and Spindle Load Monitoring for Fast Overload Shut Down
- Precision Position Display in .0001" (.002mm) Resolution.
- Electronic Handwheel for manual movement - per click: Coarse Mode .01" (.25mm) Medium Mode .001" (.01mm) Fine Mode .0001" (.002mm)
- Infinitely Variable Feedrates adjustable by handwheel during automatic cycles
- High Performance Spindle Rotation AC Brushless Servo Motor and Drive System
- Hard Chromed Precision Spindle with High Speed Angular Contact Bearings
- CAT 40 Spindle Taper with Pneumatic Quick Change Tool System
- Fast Rapid and Jog Speeds for Reduced Cycle Time
- Automatic Workhead Tilt System for Back Clearance during Surfacing
- One Piece Heat Treated Mehanite Cast Iron Machine Castings
- Turcite Coated Slideways for Low Friction and Extended Life
- Automatic Central Lubrication System monitored by computer
- LED Work Lights mounted on machine
- Chip Guard with Adjustable Pivot Arm
- Operation, Programming and Spare Parts Manual - Digital

SPECIFICATIONS

MADE IN USA

	Inch	Metric
Maximum Height - Table to Spindle Taper	40.44"	1027mm
Table Size - 5 T Slots	91.6 X 22.6"	2325 X 575mm
Maximum Distance - Spindle Center to Column	20.7"	526mm
Minimum Distance - Spindle Center to Column	8.7"	221mm
Outside Diameter of Spindle	3.8"	96.5mm
Horizontal Column Travel (X Axis)	72"	1829mm
Workhead Travel In/Out (Y Axis)	14"	355mm
Vertical Spindle Travel (Z Axis)	18"	457mm
Spindle Taper	CAT 40	
Spindle Speeds Infinitely Variable	Variable up to 1500 RPM	
Spindle Motor AC Servo Continuous Power	6HP	4.5kW
Spindle Motor AC Servo Maximum/Continuous Torque	900/360 In-lbs	100/40 NM
Cylinder Bore Range with Optional Cutterheads	.75 - 7"	19 - 178mm
Line Bore Range with Optional Cutterheads	1.9 - 5.9"	48.5 - 150mm
Surfacing Cutterhead Diameters	10 and 14"	250 and 360mm
Floor Space Requirements	153W X 94D X 118"H	3877W X 2388D X 2989mm H
Machine Dimensions	153W X 67D X 118"H	3877W X 1700D X 2989mm H
Shipping Dimensions	115W x 75D x 75"H	3886W x 1905D x 1905mm H
Machine Weight	10,000lbs	4845kgs
Power Requirement	208-240V, 40 A, 50/60 Hz, 1 Ph	
Air Requirements	1 cfm @ 90 psi	.028 L/min @ 6 Bar
Paint Color Code	RAL9002 (Grey White)	

Since 1923 Rottler Manufacturing has developed precision performance racing and engine rebuilding machinery with unmatched dedication, diversity and innovative product development. Rottler's advanced designs and equipment continue to meet the most demanding engineering needs of engine builders around the world.

Rottler offers a complete range of machines for every type of engine builder from a performance racing shop, to a diesel jobber shop or a demanding production remanufacturing facility. Rottler has a machine for your specific application. Rottler equipment is manufactured to the exacting standards demanded by the most accurate machining companies in the world.



SG7MTS Cylinder Head Valve Seat & Guide Machine



SG8MTS Cylinder Head Valve Seat & Guide Machine



SG9MTS Cylinder Head Seat & Guide Machine utilizing UNIPLOTT Tooling



SG10X CNC Cylinder Head Seat & Guide Machine



SG80MTS Heavy Duty CNC Cylinder Head Valve Seat & Guide Machine

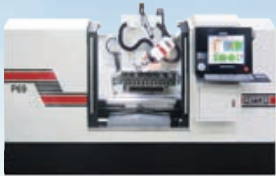

P69AHD 5-Axis CNC Cylinder Head Digitizing and Porting Machine

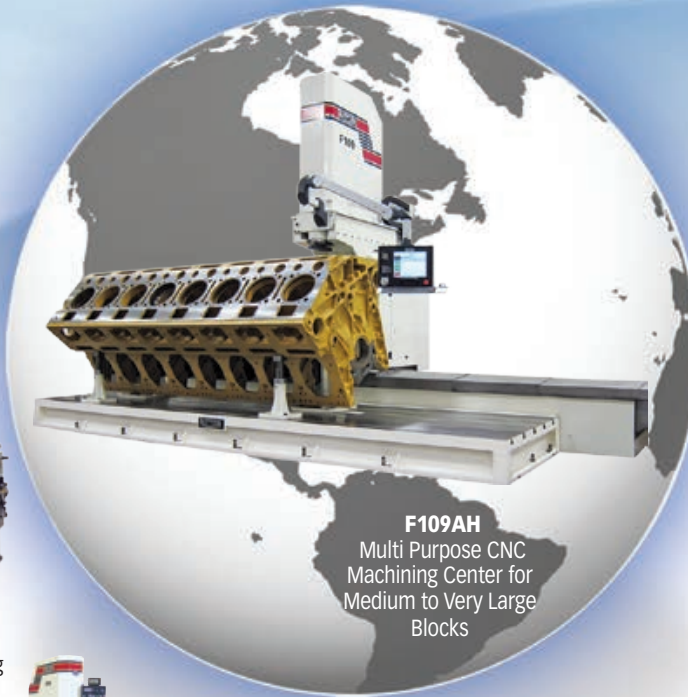

F109AH Multi Purpose CNC Machining Center for Medium to Very Large Blocks



F69ATC CNC Machining Center with Automatic Tool Changer



F10X CNC Boring/Resleeving Machine with Hole-to-Hole Automation



F10A CNC Boring/Resleeving Machine



VR9 Centerless Valve Refacing Machine



VR7 Valve Refacing Machine



H85A CNC Honing Machine



S8 Cylinder Head, Block and Manifold Surfacing Machine



F69A Multi Purpose CNC Machining Center for Small to Medium Connecting Rods

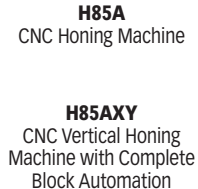

H85AXY CNC Vertical Honing Machine with Complete Block Automation



F79A Multi Purpose CNC Machining Center for Small to Medium Blocks & Heads & Conrods



F105A Multi Purpose CNC Machining Center for Medium to Large Blocks



F69A Programmable Automatic Machining Center for Small Size Blocks



September 2015

www.rottermfg.com

8029 South 200th Street
Kent, Washington 98032 USA

Represented by:

www.youtube.com/rottermfg
www.facebook.com/rottermfg
email: contact@rottermfg.com

+1 253 872 7050

1-800-452-0534