

# ROTTLER

THE CUTTING EDGE

## F70 SERIES CNC MACHINING CENTER

OPTIONAL EQUIPMENT CATALOG





## **ORDERING PROCEDURE**

Contact your regional Rottler sales rep for assistance in ordering optional equipment, replacement parts, or tooling.

If you are unable to contact your regional Rottler sales rep, call the factory at 253-872-7050 and ask to speak to the parts sales specialist.

Have the following information handy to expedite the ordering process:

1. Your name, business name, and contact number
2. Customer number
3. If you don't have a customer number, your billing address
4. Shipping address if different from billing address
5. Machine model and serial number
6. Part number and description of what you want to order
7. Preferred method of shipment

You may also contact us via e-mail with the above information. Send e-mail requests to:  
[parts@rottermfg.com](mailto:parts@rottermfg.com)

In some cases you may be requested to send a photo of the part you are ordering if it is a replacement part, or doesn't appear in the database.

If you are unsure which part you need to order, contact our service department and ask to speak to one of our service consultants. They will assist you in determining which part you require.

**THERE IS A MINIMUM ORDER OF \$25.00**



# F70 SERIES OPTIONAL EQUIPMENT CATALOG

## Contents

<b>Spare Parts for Renishaw Wireless Probe</b> .....	<b>1</b>
6648U Spare Battery.....	1
650-3-59C 50mm long X 6mm diameter Stylus.....	1
650-3-59D 100mm long X 6mm diameter Stylus.....	1
650-3-59E 20mm long X 2mm diameter Stylus.....	1
650-3-59K 50mm Extension for 50mm & 100mm Stylus.....	1
6648T 10mm Stylus Extension.....	1
6648Q 17.5mm long X 6mm diameter Stylus.....	1
<b>Fixturing</b> .....	<b>2</b>
650-3-30 Block End Truing Fixture Assembly.....	2
650-3-30A Block End Truing Fixture Assembly.....	3
650-3-20A Pan Rail Wedge Fixture.....	4
650-3-84 Overhead Cam Block Fixture for V6 V8 engines, 4th Axis.....	6
<b>Miscellaneous Accessories</b> .....	<b>7</b>
650-3-82 Mopar 5.7L Hemi Fixture Assembly.....	7
7242M Clamp Tower Assembly.....	8
7241P Rottler Economy Head and Block Fixture Assembly.....	9
650-3-37 1/2" (12.7mm) Universal Clamping Kit.....	10
650-2-11H Combination Grit Sharpening Stone.....	10
650-2-45H 1" (25.4mm) Diameter Roughing End Mill.....	10
<b>Gages and Indicators</b> .....	<b>11</b>
650-3-38 Level-Intake and Exhaust Manifolds.....	11
7152A Dual Axis Level Assembly.....	11
502-9-9G Three Dimensional Electronic Position Finder.....	11
502-9-9A Mechanical Run Out Indicator.....	12
502-11-39D Mechanical Run Out Indicator.....	12
502-12-4 Magnetic Base.....	12
<b>Boring/Sleeving/Chamfering/O-Ring Tooling</b> .....	<b>13</b>
650-2-1D Cutterhead Package.....	13
650-2-14B Cutterhead Package.....	14
11100 Cutterhead Assembly.....	15



**11101 Cutter Head..... 16**

**Extender for 650-2-14,11100, and 11101 Cutterheads ..... 17**

**650-2-16D 1.400” (35.56mm) Spacer ..... 17**

**Miscellaneous Tooling for 650-2-14, 11100, and 11101 Cutterheads ..... 17**

501-29-6K PCD Tipped Triangular Insert ..... 17

6598M Cartridge, Triangular ..... 17

6598K Cartridge, Indexable Insert Assembly..... 17

6598R Cartridge Assembly ..... 17

6599 Cartridge, Traingular, Zero Rake ..... 17

6599D Cartridge, Traingular, Zero Rake ..... 17

6260L Cartridge Square Negative Rake..... 17

6260W Cartridge, Square, Negative Rake ..... 17

6513J Tool Bit ..... 17

6513L Tool Bit ..... 18

6513N Tool Bit..... 18

6513Q Tool Bit..... 18

6513P Tool Bit ..... 18

6747K Cartridge Assembly - 5 Degree Chamfer ..... 18

6747P Cartridge Assembly - 10 Degree Chamfer ..... 18

6747G Cartridge Assembly - 15 Degree Chamfer ..... 18

6747F Cartridge Assembly - 20 Degree Chamfer ..... 18

6747M Cartridge Assembly - 20 Degree Chamfer..... 18

6747H Cartridge Assembly - 30 Degree Chamfer ..... 18

6593L Cartridge Assembly..... 19

6593M Cartridge Assembly..... 19

6593N Cartridge Assembly ..... 19

6593P Cartridge Assembly ..... 19

RT211 Insert ..... 19

RT212 Insert..... 19

RT321 Insert..... 19

RT322 Insert..... 19

RT321F Insert..... 20

RT322F Insert..... 20

RTS321 Insert..... 20

RTS322Insert..... 20

RS322 Insert..... 20

**Surfacing Tooling ..... 21**

**650-2-8E Surfacing Cutterhead, Flycutter, 10” (254mm) Diameter ..... 21**

**650-2-8F Surfacing Cutterhead, Flycutter, 14” (356mm) Diameter ..... 21**

6303B CBN Insert ..... 22



6303M Pcd Insert ..... 22

6303K Coated Carbide Insert..... 22

6303S CBN Insert..... 22

6303U CBN Round Insert ..... 22

6303V CBN Insert, Octagonal ..... 22

**Surfacing Fixtures ..... 23**

7209M Leveling Table with Airfloat ..... 23

7209N 2-Piece Vise ..... 24

7152A Dual Axis Level Assembly..... 25

**Main Line Bore Tooling ..... 26**

11103E Main Line Bore 90 Degree Right Angle Drive Assembly..... 26

11104 Special Belt Drive 90 Degree Right Angle Drive Assembly ..... 27

11105 Narrow Right Angle Drive 1.9 - 2.4” (48 - 60.9mm) ..... 28

650-2-39B Cutterhead Package Line Boring 1.9 - 4.0” (48.26 - 101.60mm) Diameter..... 29

650-2-39C Cutterhead Package Line Boring 2.9 - 5.6” (73.66 - 142.24mm) Diameter..... 30

**Tooling For Cutterheads 650-2-39B & 650-2-39C ..... 31**

6801B Tool holder Assembly..... 31

6801C Tool holder Assembly, Indexable ..... 31

6801D Tool holder Assembly..... 31

6801E Tool holder Assembly ..... 31

6801F Tool holder Assembly ..... 31

6801G Tool holder Assembly..... 31

6801H Tool holder Assembly..... 31

6801J Tool holder Assembly ..... 31

**Special Main Line Boring Thrust Facing Tooling ..... 32**

6801M Tool Holder..... 32

6801P Tool Holder Package..... 32

501-29-6G Insert, Triangular ..... 32

501-29-6J Insert ..... 32

501-29-6H Insert Screw ..... 32

**Special Main Line Boring Chamfering Tooling ..... 32**

199-90 Tool Holder..... 32

199-96 Tool Holder..... 32

501-33E Tool Bit..... 32

**Equipment for Centering In Bores ..... 33**

502-12-4A Magnetic Indicator Holder Assembly..... 33

502-9-9A Mechanical Run Out Indicator ..... 33

502-12-4 Magnetic Base ..... 33

<b>Cam Line Boring Tooling .....</b>	<b>34</b>
<b>650-3-43T Cam Line Bore Tooling Package .....</b>	<b>34</b>
<b>Cam Line Bar Bushings .....</b>	<b>36</b>
650-3-43B Bushing - 62.992mm (2.480" +/- .0007) .....	36
650-3-43C Bushing - 57.963mm (2.282" +/- .0007) .....	36
650-3-43D Bushing - 57.150mm (2.250" +/- .0007) .....	36
650-3-43E Bushing - 70.866mm (2.790" +/- .0007) .....	36
650-3-43F Bushing - 58.649mm (2.309" +/- .0007) .....	36
650-3-43G Bushing - 63.500mm (2.500" +/- .0007) .....	36
650-3-43H Bushing - 53.848mm (2.120" +/- .0007) .....	37
650-3-43J Bushing - 51.562mm (2.030" +/- .0007) .....	37
650-3-43K Bushing - 51.816mm (2.040" +/- .0015) .....	37
650-3-43L Bushing - 60.960mm (2.400" +/- .0007) .....	37
650-3-43M Bushing - 53.975mm (2.125" +/- .0007) .....	37
650-3-43N Bushing - 54.610mm (2.150" +/- .0007) .....	37
650-3-43P Bushing - 58.420mm (2.300" +/- .0007) .....	38
650-3-43Q Bushing - 52.324mm (2.060" +/- .0007) .....	38
650-3-43R Bushing - 67.902mm (2.6733" +/- .0007) .....	38
650-3-43S Bushing - 51.943mm (2.0450 +/- .0007) .....	38
<b>Lifter Bore Tooling .....</b>	<b>39</b>
<b>650-2-60B Lifter Bore Tooling Kit .....</b>	<b>39</b>
<b>650-2-20C End mill .....</b>	<b>40</b>
<b>650-2-20L End mill .....</b>	<b>40</b>
<b>T8D Torx Wrench .....</b>	<b>40</b>
<b>650-2-60M T5 Torx Wrench .....</b>	<b>40</b>
<b>650-2-44A End Mill Adapter .....</b>	<b>40</b>
<b>650-2-44L CAT 40 Retention knob .....</b>	<b>40</b>
<b>650-2-60C Boring Bar .....</b>	<b>40</b>
<b>650-2-60E Cartridge with dial assembly .....</b>	<b>40</b>
<b>650-2-60G Insert for 0.750 - 0.900 diameter cartridge .....</b>	<b>40</b>
<b>650-2-60J Wrench .....</b>	<b>40</b>
<b>650-2-60D Boring Bar .....</b>	<b>41</b>
<b>650-2-60F Cartridge only .....</b>	<b>41</b>
<b>650-2-60H Insert .....</b>	<b>41</b>
<b>650-2-60K Wrench .....</b>	<b>41</b>
<b>650-2-60L Hardware kit .....</b>	<b>41</b>
<b>Lifter Bore Bushing Installation Tooling .....</b>	<b>42</b>
<b>11117A 31mm Lifter Sleeve Press Tool .....</b>	<b>42</b>



<b>11117B 26.9mm Lifter Sleeve Press Tool</b> .....	<b>42</b>
<b>Spacers Required for the Performance Fixture #650-3-1</b> .....	<b>42</b>
650-3-7E 4-Degree Cam Bar Spacer.....	42
650-3-7F 6.25 Degree Cam Bar Spacer .....	42
650-3-7G Spacer, Cam Bar 3.5 Degree.....	42
650-3-7H Spacer, Cam Bar 4-Degree.....	43
650-3-7J Spacer Cam Bar 48-Degree .....	43
650-3-7N Spacer, Cam Bar 42-Degree.....	43
650-3-7P Spacer, Cam Bar 43-Degree.....	43
650-3-7Q Spacer, Cam Bar 44-Degree .....	43
650-3-7S Spacer, Cam Bar 44-Degree.....	43
650-3-7T Spacer, Cam Bar 48-Degree.....	43
<b>Complete Listing Of CAT 40 Taper End Mill Holders</b> .....	<b>44</b>
650-2-44J Adaptor 1/2" (12.70mm).....	44
650-2-44S Adaptor 5/8" (15.875mm) .....	44
650-2-44C Adaptor 3/4" (19.05mm) .....	44
650-2-44B Adaptor 7/8" (22.225mm) .....	44
650-2-44A Adaptor 1" (25.40mm) .....	44
650-2-44K Adaptor 1-1/4" (31.75mm).....	44
<b>Thread Tapping Tooling</b> .....	<b>45</b>
650-2-11K Quick Change Tap Holder Cartridge Assembly with Adaptor .....	45
650-2-11B Quick Change Straight Shank Tap Holder Cartridge.....	45
<b>Torque Control Tap Holders</b> .....	<b>45</b>
650-2-11C Torque Control Tap Holder .....	45
650-2-11D Torque Control Tap Holder .....	45
650-2-11E Torque Control Tap Holder.....	45
650-2-11F Torque Control Tap Holder .....	45
650-2-11G Torque Control Tap Holder .....	45
<b>Drill Tooling</b> .....	<b>46</b>
650-2-44M Precision Drill Chuck Assembly .....	46
650-2-9A Drill Chuck Adaptor .....	46
650-2-9B Drill Chuck 1/8-5/8" (3.175-15.875mm) With Key .....	46
650-2-44N 2 1/2" (63.50mm) Shell Mill Assembly .....	47
650-2-44G Shell Mill Holder .....	47
7224E 2 1/2" (63.50mm) Shell Mill.....	47
6514T Cutting Inserts.....	47
7224D Socket Head Cap Screw .....	47
650-2-44L CAT 40 Retention knob.....	47
<b>650-2-44P 4" (101.60mm) Shell Mill Assembly</b> .....	<b>48</b>



**650-2-44F** Shell Mill Holder ..... 48

**7224F 4” (101.60mm) Shell Mill** ..... 48

**6514T** Cutting Inserts ..... 48

**650-2-26B** Mounting Bolt ..... 48

**650-2-44L** CAT 40 Retention knob..... 48

**650-2-44W** Block Lightening Tooling Package for Dart Small Block Chev ..... 49

**650-2-44X** Block Lightening Tooling Package for World Products Small Block Chev ..... 51

**650-2-45J** Block Lightening Tooling Package for Big Block Chevy ..... 53

**650-2-45Q** Big Block Main Cap Lightening Fixture Assembly with Tooling..... 54

**Connecting Rod Fixturing And Tooling**..... 55

**650-3-44S** Rottler Precision Connecting Rod Fixturing System..... 55

**650-2-3S** Cutterhead Package ..... 56

**650-2-3T** Cutterhead Package ..... 57

**650-2-15F** Cutterhead Package ..... 58

**RTCR322** Insert, Triangular Positive Rake, 3/8 IC 1/64” (9.397mm) Radius..... 58

## Spare Parts for Renishaw Wireless Probe

<p><b>6648U Spare Battery</b> for Renishaw probe (2 Required)</p> 	<p><b>650-3-59C 50mm long X 6mm diameter Stylus</b></p> 
<p><b>650-3-59D 100mm long X 6mm diameter Stylus</b></p> 	<p><b>650-3-59E 20mm long X 2mm diameter Stylus</b></p> 
<p><b>650-3-59K 50mm Extension for 50mm &amp; 100mm Stylus</b></p> 	<p><b>6648T 10mm Stylus Extension</b></p> 
<p><b>6648Q 17.5mm long X 6mm diameter Stylus</b></p> 	

## Fixturing

### 650-3-30 Block End Truing Fixture Assembly

(Requires Performance Fixture Part #650-3-19) Used for Surfacing and Machining Front and Rear End of Block True to Crankshaft Centerline.

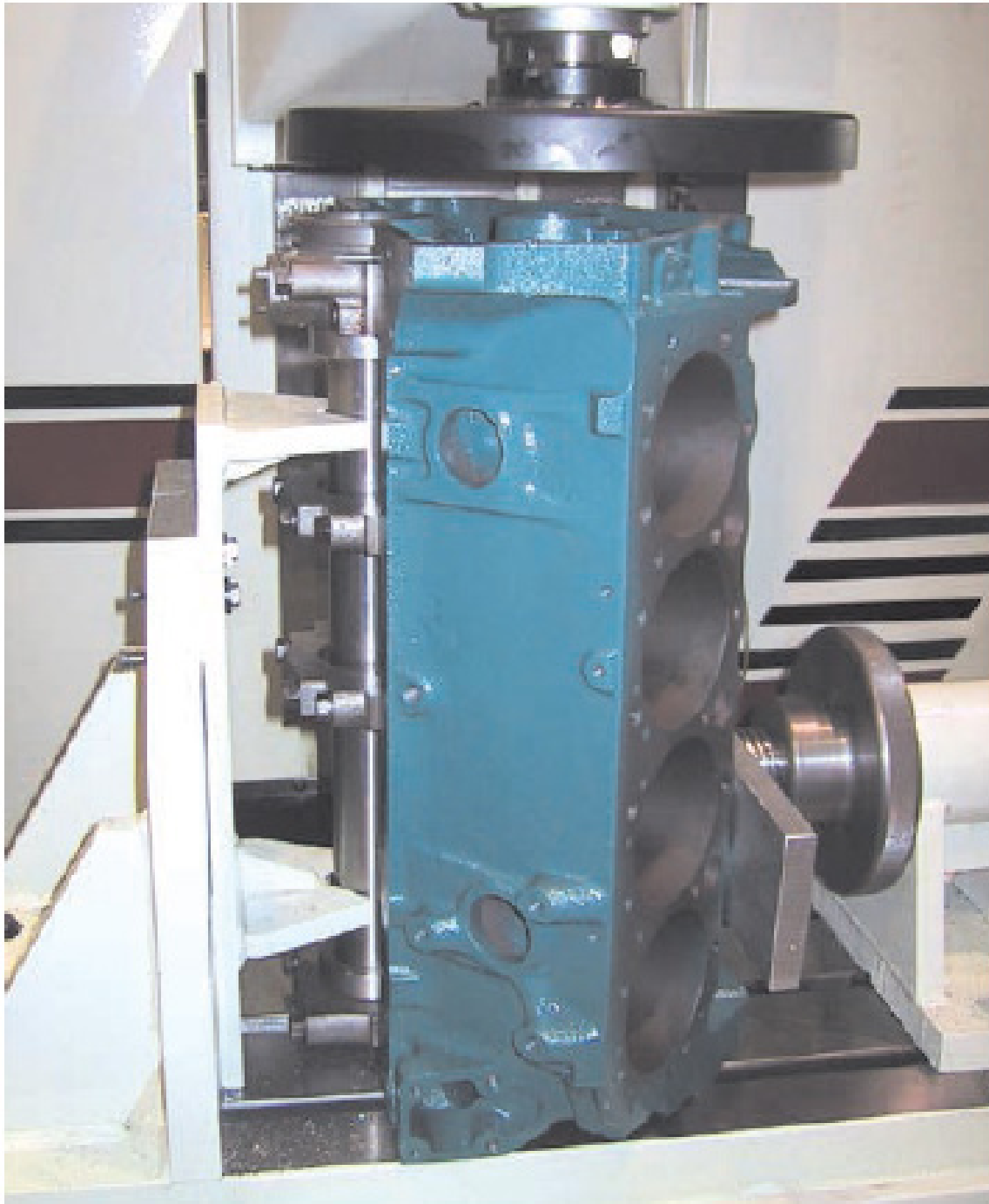

**650-3-30A Block End Truing Fixture Assembly**

(Requires 4th Axis Fixture #650-3-59) Used for Surfacing and Machining Front and Rear End of Block True to Crankshaft Centerline.



**650-3-20A Pan Rail Wedge Fixture**

(Requires Performance Fixture Part #650-3-1). Used for Fixturing 60 & 90-Degree OHC Blocks

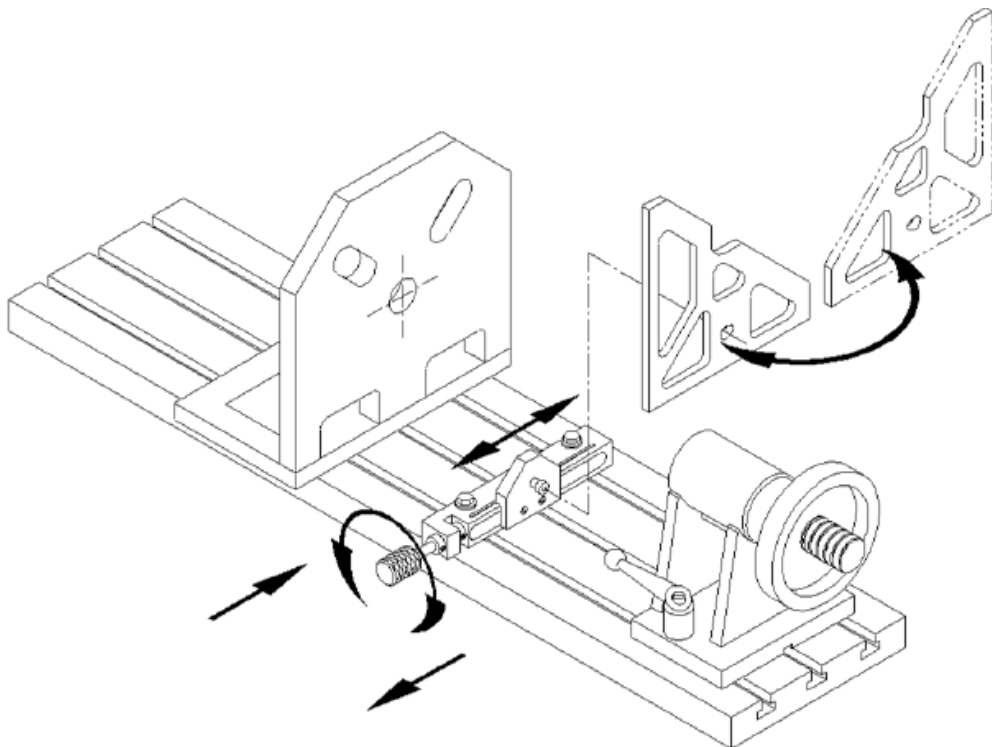
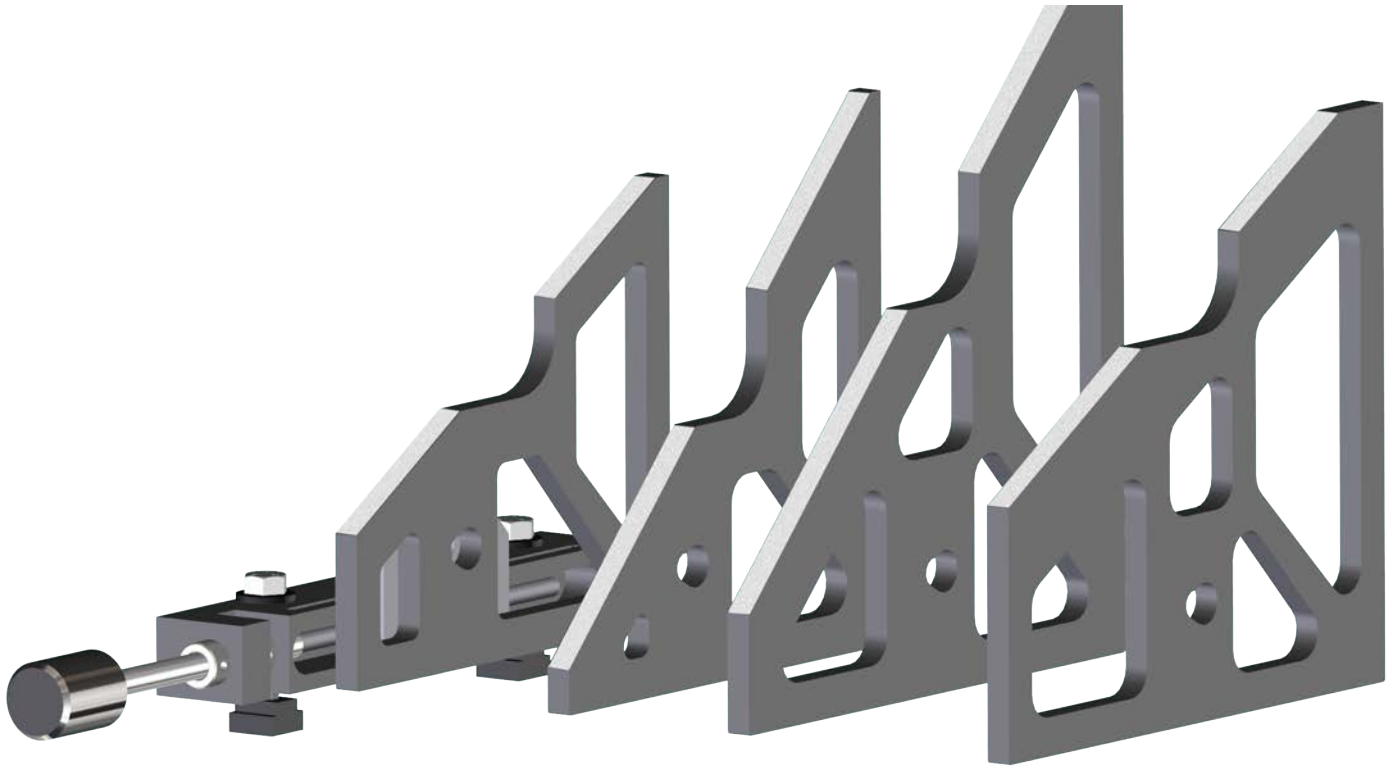

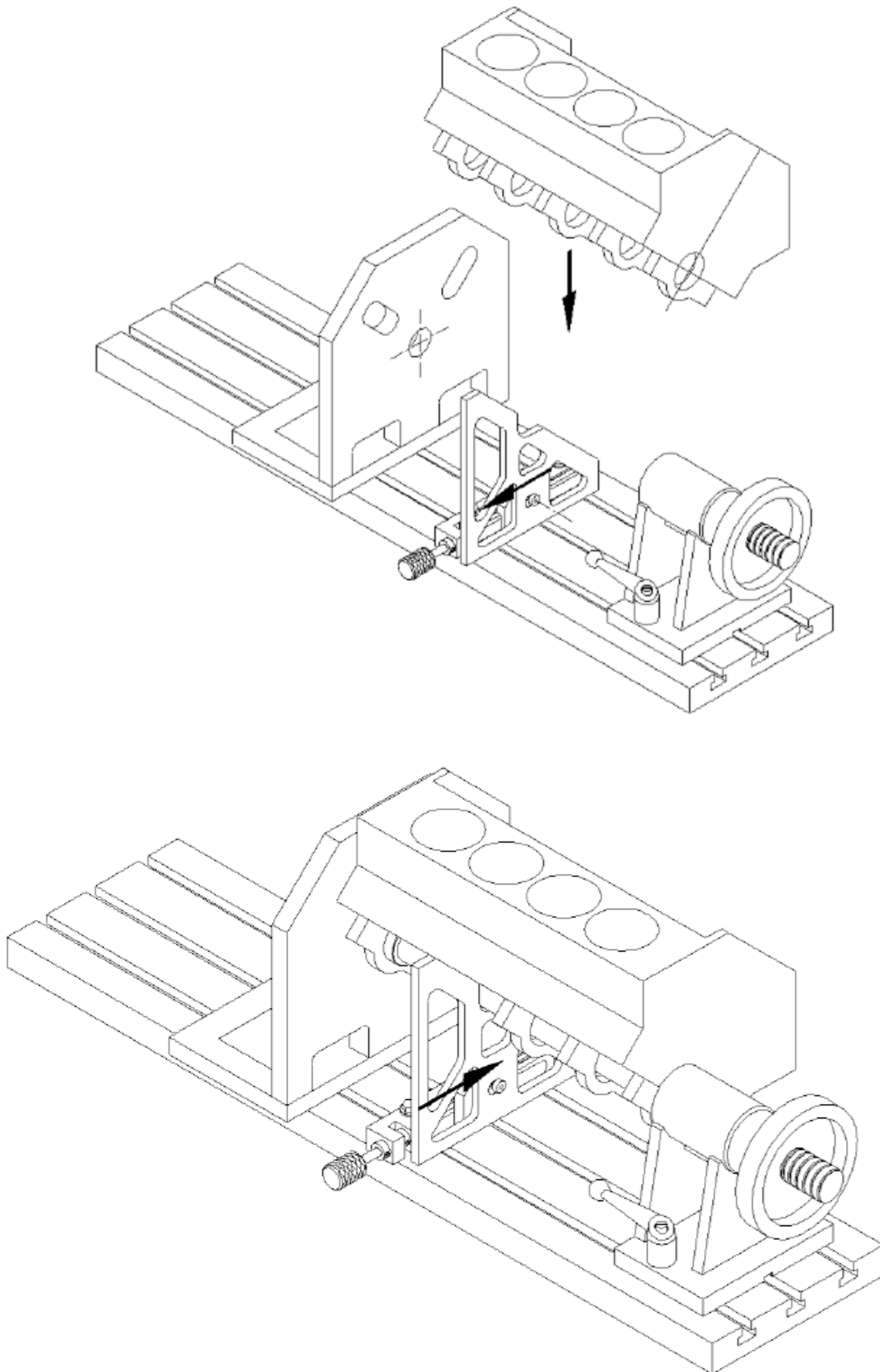

### 650-3-84 Overhead Cam Block Fixture for V6 V8 engines, 4th Axis

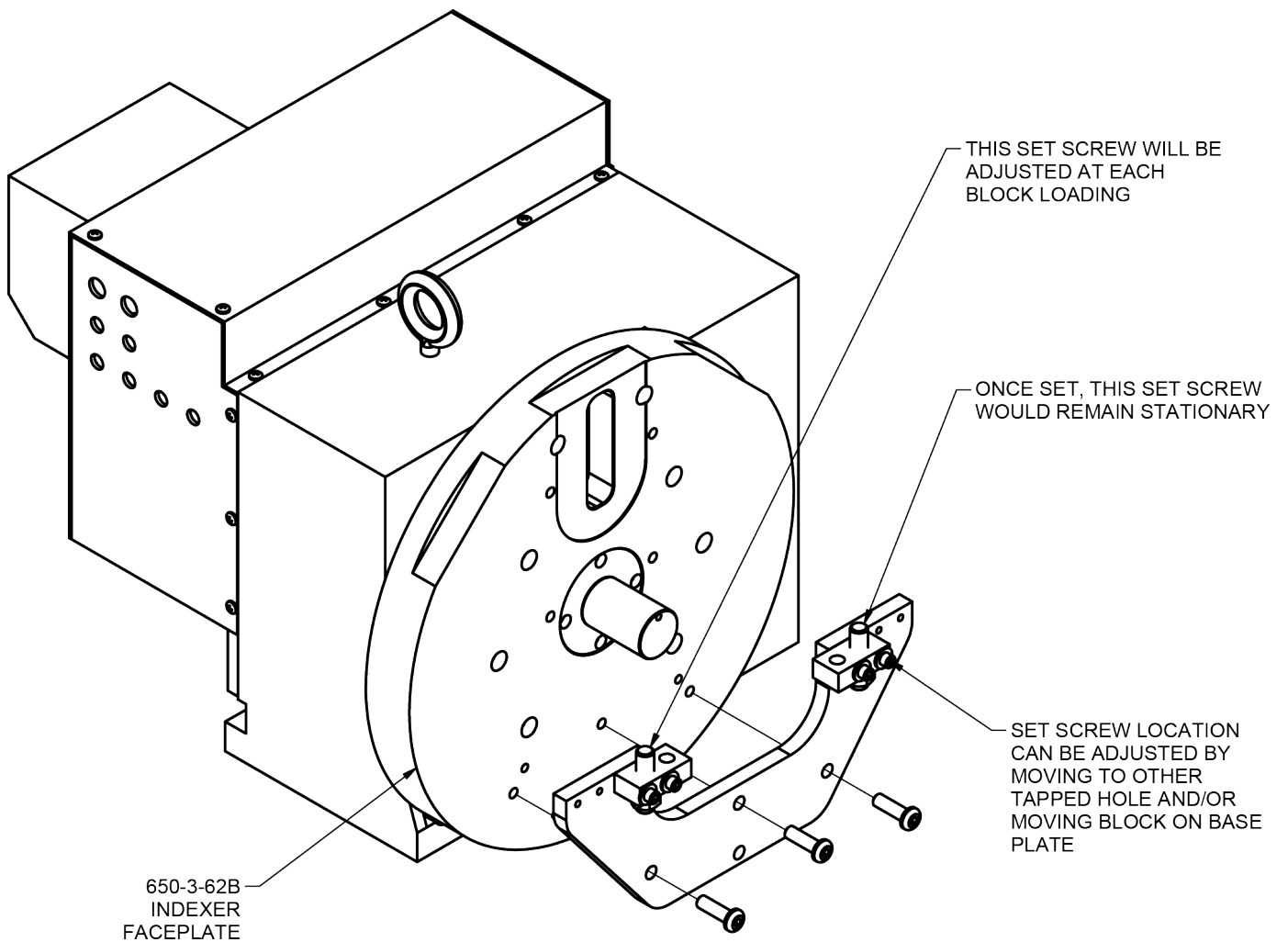
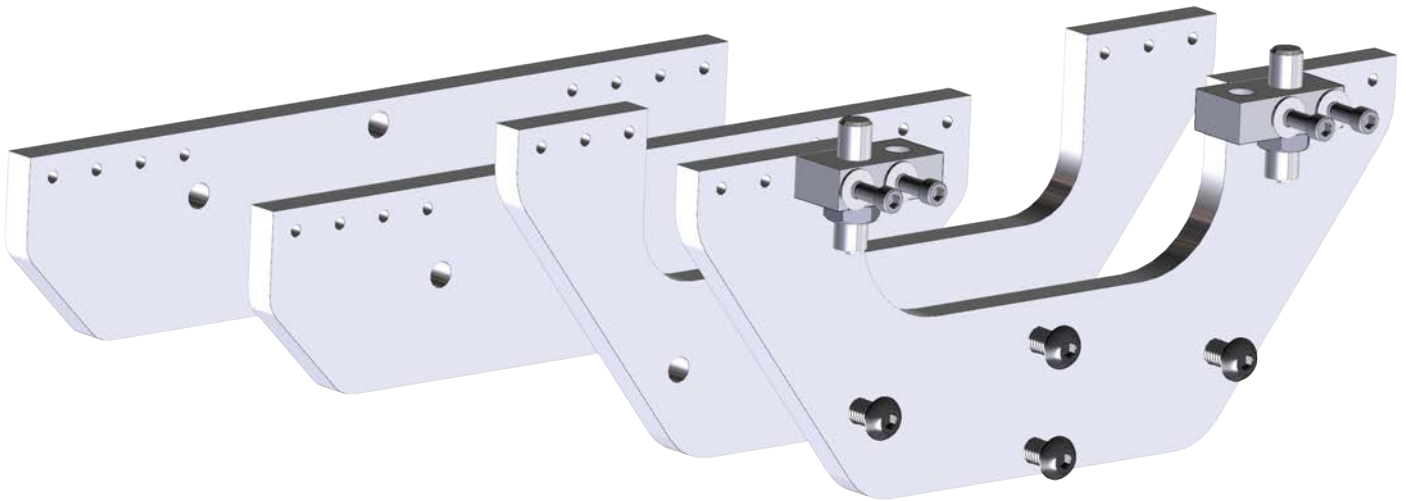



### Miscellaneous Accessories

#### 650-3-82 Mopar 5.7L Hemi Fixture Assembly

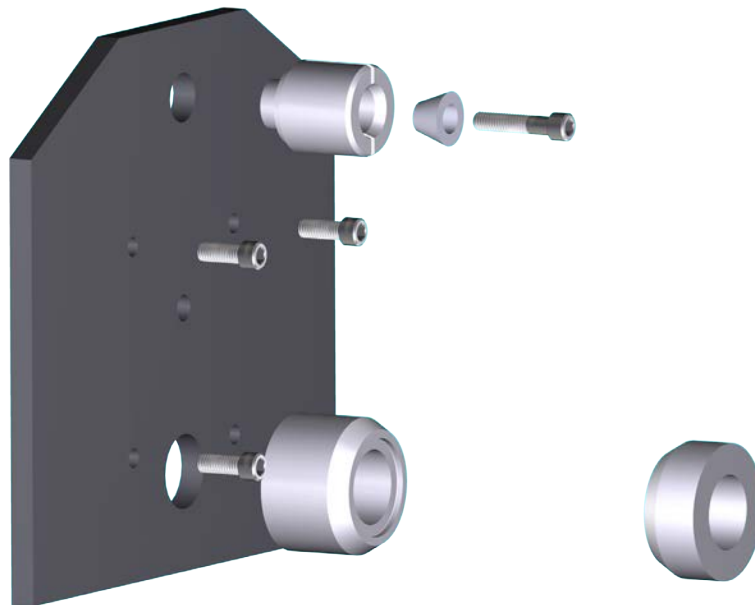
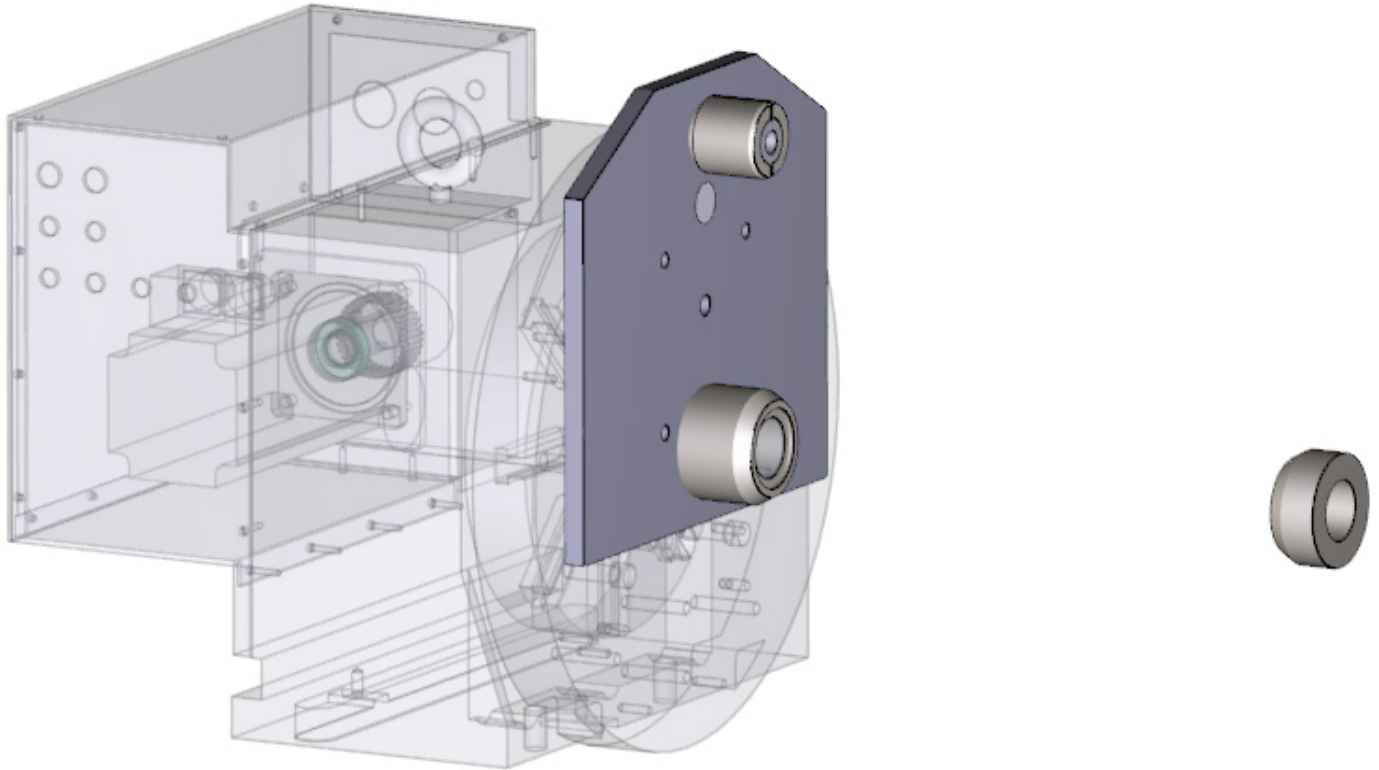

**7242M Clamp Tower Assembly**



**7241P Rottler Economy Head and Block Fixture Assembly**

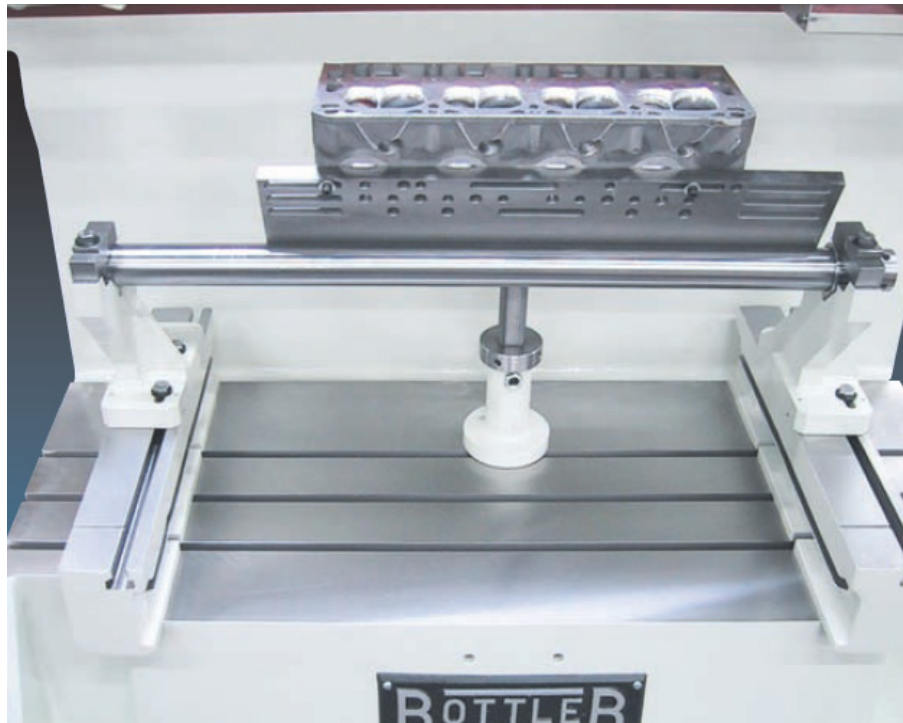
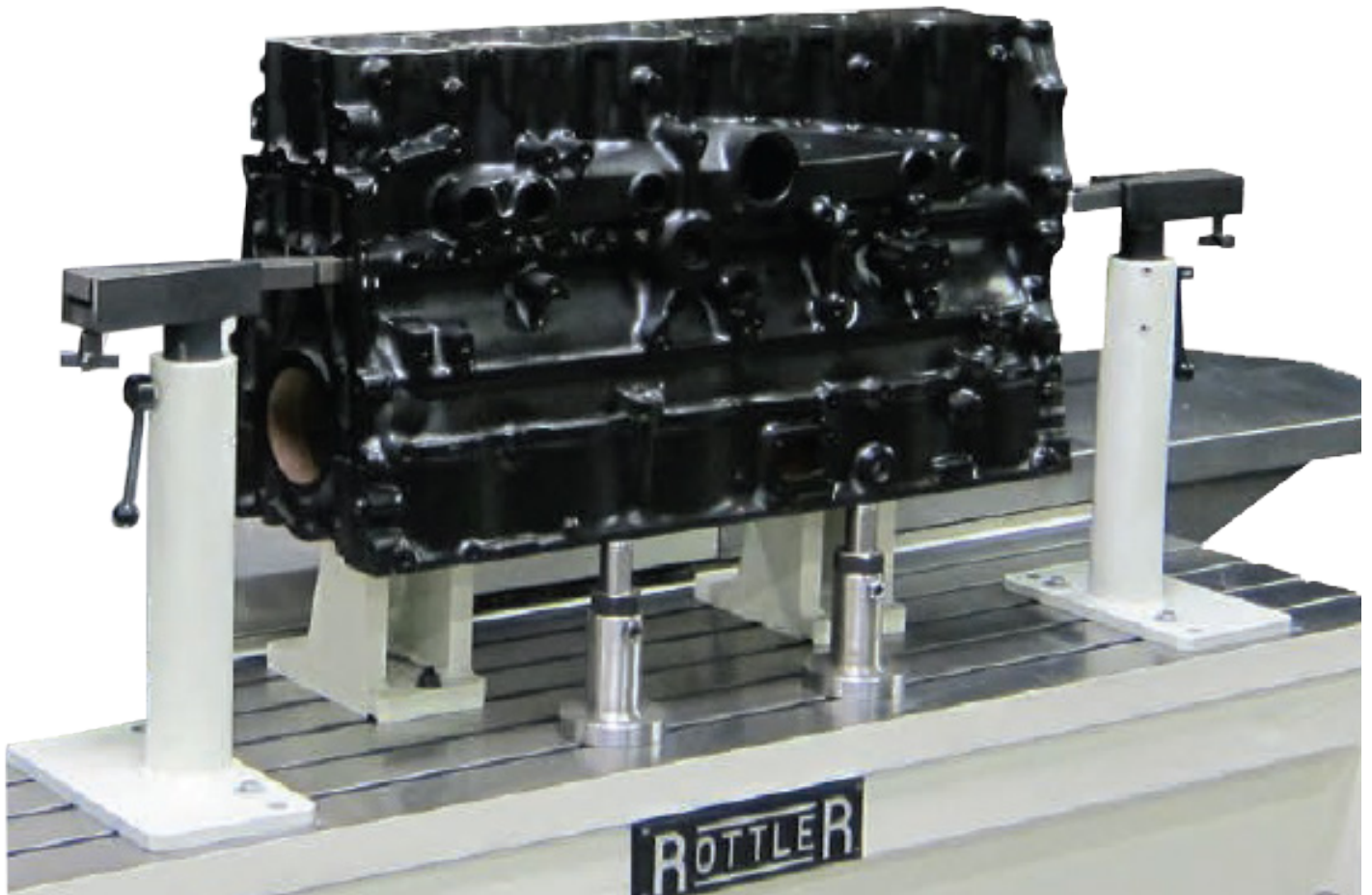

**650-3-37 1/2" (12.7mm) Universal Clamping Kit**

Including T-Nuts, Bolts, Studs, Strap Clamps, Etc.

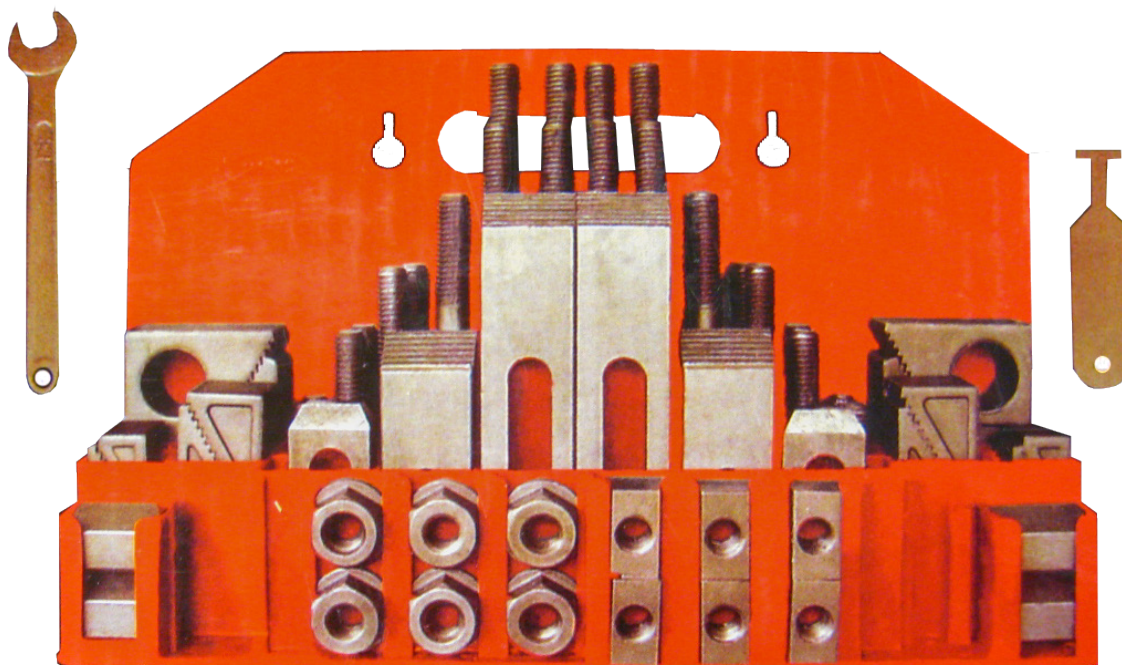
**650-2-11H Combination Grit Sharpening Stone**

6 X 2 X 1" (152.40 X 50.80 X 25.40mm)

**650-2-45H 1" (25.4mm) Diameter Roughing End Mill**

8 1/2" (215.90mm) long for block stroker clearance





## Gages and Indicators

### 650-3-38 Level-Intake and Exhaust Manifolds



### 7152A Dual Axis Level Assembly



### 502-9-9G Three Dimensional Electronic Position Finder

With Spindle Adaptor



**502-9-9A Mechanical Run Out Indicator**  
 General Purpose (.001 Resolution)



**502-11-39D Mechanical Run Out Indicator**  
 For Precision Bore Adjustment (.0001 Resolution)



**502-12-4 Magnetic Base**  
 Including (2) Extension Arms for Indicators

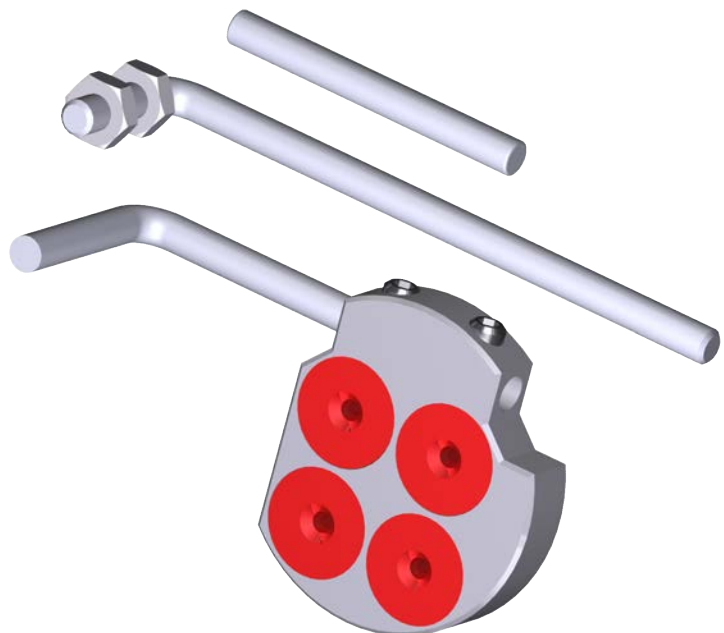

## Boring/Sleeving/Chamfering/O-Ring Tooling

### 650-2-1D Cutterhead Package

2.0 - 4.0" (50.80 - 101.60mm) diameter X 7.0" (177.80mm) length complete with tooling and Digital Micrometer as Listed Below:

- (1) 650-2-1E Cutterhead Assembly
- (1) 501-72J Hex Driver - 3/16" (4.775mm)
- (1) 6801B Tool Holder, 2.0 - 2.4" (50.80 - 60.96mm) diameter, 1/4" (6.35mm) Triangular-Positive Rake
- (1) 6801C Tool Holder, 2.4 - 2.8" (60.96 - 71.12mm) diameter, 3/8" (9.525mm) Triangular-Positive Rake
- (1) 6801D Tool Holder, 2.8 - 3.2" (71.12 - 81.28mm) diameter, 3/8" (9.525mm) Triangular-Positive Rake
- (1) 6801E Tool Holder, 3.2 - 3.6" (81.28 - 91.44mm) diameter, 3/8" (9.525mm) Triangular-Positive Rake
- (1) 6801F Tool Holder, 3.6 - 4.0" (91.44 - 101.60mm) diameter, 3/8" (9.525mm) Triangular-Positive Rake
- (1) T8D Wrench-Torx - 1/4" (6.35mm) Triangular Insert Holder
- (1) 511-29-12D Wrench-Torx - 3/8" (9.525mm) Triangular Insert Holder
- (1) RT212 Insert, Triangular 1/4" (6.35mm) 1/32 Radius (1/4 Triangle Insert Holders Only) General Purpose and Sleeving
- (1) RT211 Insert, Triangular 1/4" (6.35mm) 1/64 Radius (1/4 Triangle Insert Holders Only) General Purpose and Sleeving
- (1) RT321 Insert, triangular positive rake, 3/8" (9.525mm) 1/64" (.397mm) radius, general purpose and sleeving.
- (1) RT322 Insert, triangular positive rake, 3/8" (9.525mm) 1/32" (.787mm) radius, general purpose and sleeving.
- (1) 900-2-19 Universal Micrometer Assembly Digital Reading (Inch and Metric) for 1/2" (12.7mm) Tooling



### 650-2-14B Cutterhead Package

2.9 - 5.0" (73.66 - 127.00mm) diameter X 7.0" (177.80mm) length complete with tooling and Digital Micrometer as Listed Below:

- (1) 650-2-14C Cutterhead Assembly
- (1) 900-2-20 Universal Micrometer Assembly Digital Reading (Inch and Metric) for 3/4" Tooling
- (1) 6593C Tool Holder, 2.9 - 3.4" (73.66 - 86.36mm) diameter, 3/8" (9.525mm) Triangular-Positive Rake
- (1) 6593D Tool Holder, 3.4 - 3.9" (86.36 - 99.06mm) diameter, 3/8" (9.525mm) Triangular-Positive Rake
- (1) 6520H Tool Holder, 2-1/4" (57.15mm), 3.75 - 4.0" (95.25 - 101.60mm) diameter
- (1) 6520A Tool Holder, 2-3/8" (60.325mm), 4.0 - 4.5" (101.60 - 114.30mm) diameter
- (1) 6520B Tool Holder, 2-5/8" (66.675mm), 4.5 - 5.0" (114.30 - 127mm) diameter
- (1) 6260L Cartridge Assembly, Indexable Insert 1-7/8" (47.625mm) for Square Negative Rake Inserts
- (1) 6260W Cartridge Assembly, Indexable Insert-Offset for Square Negative Rake Inserts
- (1) RS322 Insert, Square Negative Rake, 1/32" (.787mm) Radius, 3/8 IC, Black Ceramic Coated for High Speed Oversize Through Boring
- (1) 6598M Cartridge Assembly, Indexable Insert 1-3/8" (34.925mm) for Triangular Positive Rake Inserts
- (2) RT321 Insert, triangular positive rake, 3/8" (9.525mm) 1/64" (.397mm) radius, general purpose and sleeving.
- (2) RT322 Insert, triangular positive rake, 3/8" (9.525mm) 1/32" (.787mm) radius, general purpose and sleeving.
- (1) 511-29-12D Wrench-Torx-3/8" (9.525mm) Triangular Insert Holder
- (1) 501-72B Wrench-Allen, 3/32" (2.388mm)
- (1) 501-72E Wrench-Allen, 3/16" (4.775mm)
- (1) 100-24 Tool Puller





## 11100 Cutterhead Assembly

3.8 - 5.0" (96.52mm - 127.00mm) Diameter Complete with Tooling and Digital Micrometer as listed below:

- (1) 900-2-20 Universal Micrometer Assembly Digital Reading Inch and Metric (for 3/4" tooling)
- (1) 6520H Tool Holder, 2 1/4" (57.15mm) Long, Diameter Bore Range 3-3/4 - 4" (95.25 - 102mm)
- (1) 6520A Tool Holder, 2 3/8" (60.325mm) Long, Diameter Bore Range 4 - 4-1/2" (102 - 114mm)
- (1) 6520B Tool Holder, 2 5/8" (66.675mm) Long, Diameter Bore Range 4-1/2 - 5" (114 - 127mm)
- (1) 6598M Cartridge, Indexable Insert Assembly - 13/16" (20.65mm) Shank Length for Triangular Positive Rake Inserts (1 3/8" [34.925mm] Overall Length)
- (1) 6598R Offset Cartridge, Indexable Positive Rake
- (2) RT321 Insert, Triangular Positive Rake - 3/8 IC 1/64 Radius
- (2) RT322 Insert, Triangular Positive Rake - 3/8 IC 1/32 Radius
- (1) 511-29-12D Wrench, Torx Triangular Insert Cartridge Tool holders
- (1) 501-72B Wrench, Allen 3/32" (2.388mm)
- (1) 501-72E Wrench, Allen 3/16" (4.775mm) F80 Series
- (1) 501-72 Driver, Hex - 7/32" (5.556mm) Ball Nose
- (1) 100-24 Puller, Tool
- (1) 501-72J Driver, Hex - 3/16" (4.775mm)
- (1) Wrench, Micrometer (For Inch/Metric Mic Heads)
- (1) 11100A Cutterhead Assembly w/out Tooling

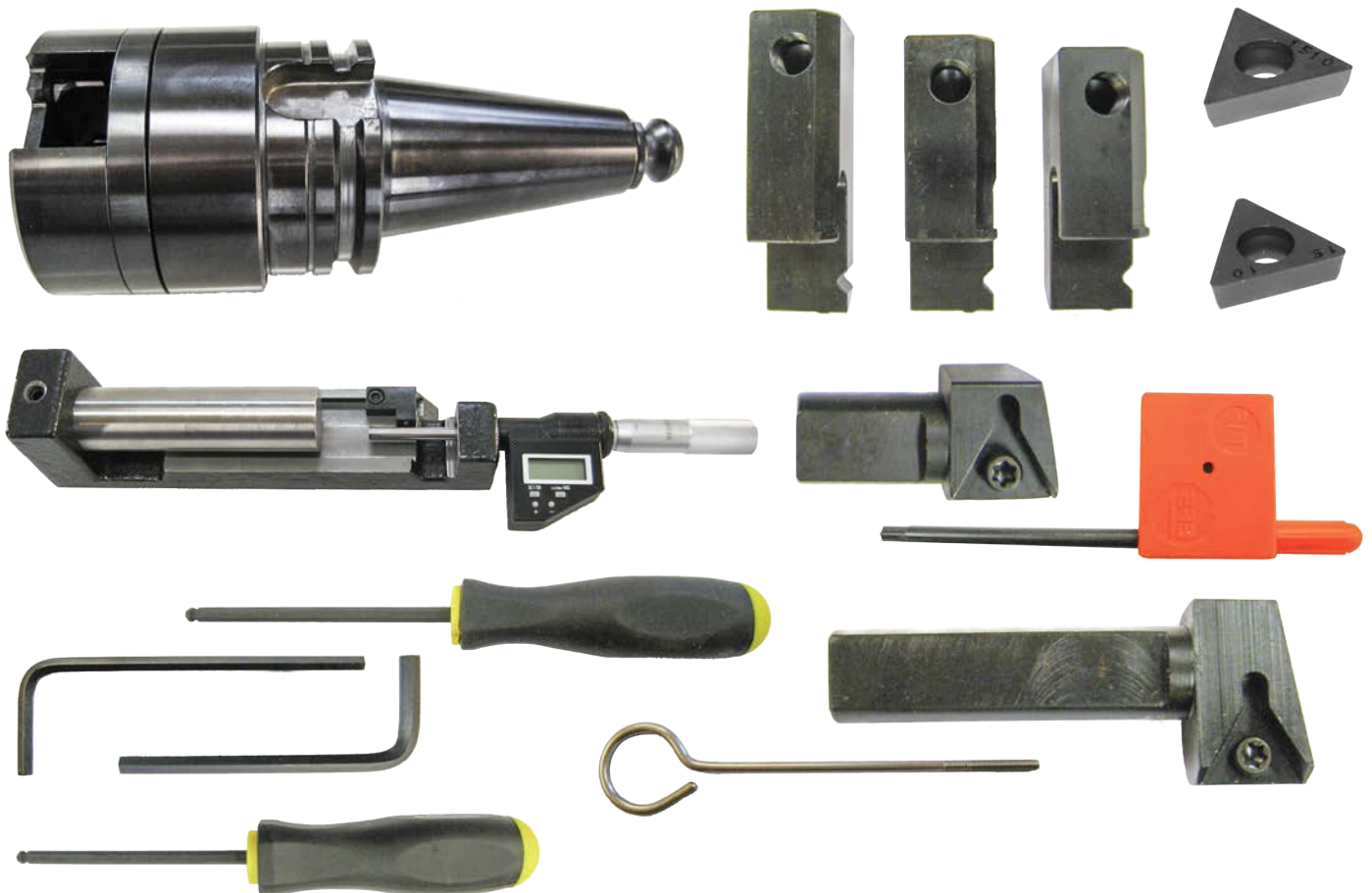

## 11101 Cutter Head

Heavy Duty 4.5 x 7.0" (115 x 178mm) Diameter Complete with Tooling and Digital Micrometer as Listed Below:

- (1) 900-2-20 Universal Micrometer Assembly Digital Reading (inch and metric) for 3/4" (19.05MM) tooling
- (1) 6259P Tool Holder 3-1/8" (79.375mm) long, Diameter Bore Range 4-1/2 - 4-3/4" (114 - 121mm)
- (1) 6259C Tool Holder 3-3/8" (85.725mm) long, Diameter Bore Range 4-3/4 - 5" (121 - 127mm)
- (1) 6259D Tool Holder 3-5/8" (92.075mm) long, Diameter Bore Range 5 - 5-1/2" (127 - 140mm)
- (1) 6259I Tool Holder 3-7/8" (98.425mm) long, Diameter Bore Range 5-1/2 - 6" (140 - 152mm)
- (1) 6259E Tool Holder 4-1/8" (104.775mm) long, Diameter Bore Range 6 - 7" (152 - 178mm)
- (1) 6598K Triangular Indexable insert holder assembly, positive rake, 2-15/32" (62.713mm) long
- (1) 6598M Triangular Indexable insert holder assembly, positive rake, 1-3/8" (34.925mm) long
- (1) 6598R Offset Cartridge, Indexable Positive Rake
- (2) RT321 Insert, triangular positive rake, 3/8" (9.525mm) 1/64" (.397mm) radius, general purpose and sleeving.
- (2) RT322 Insert, triangular positive rake, 3/8" (9.525mm) 1/32" (.787mm) radius, general purpose and sleeving.
- (1) 511-29-12D Torx wrench for cartridge tool holders
- (1) 11101A CUTTERHEAD WITHOUT TOOLING

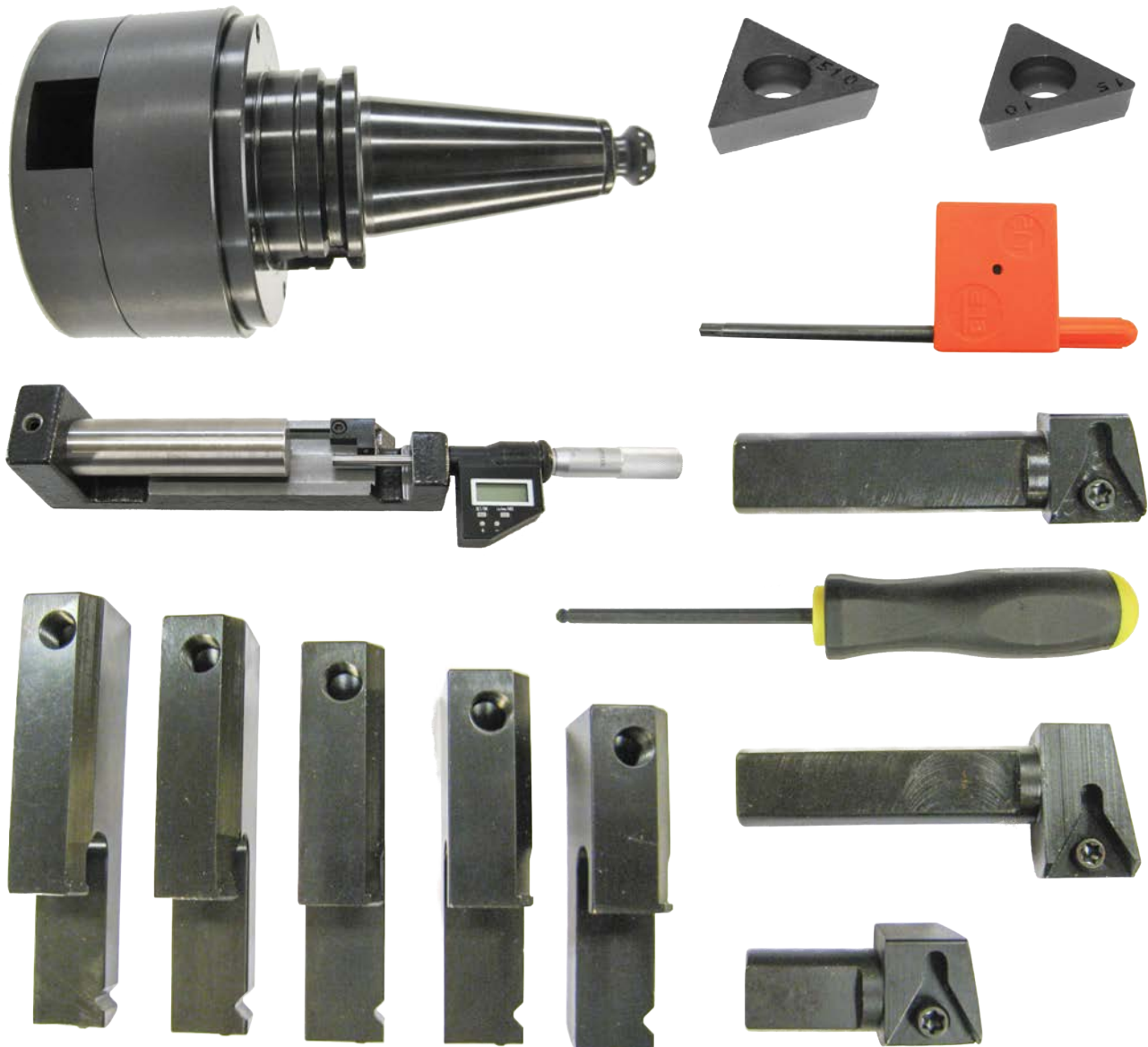









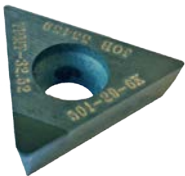





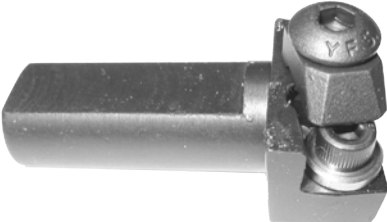



**Extender for 650-2-14,11100, and 11101 Cutterheads**

**650-2-16D 1.400" (35.56mm) Spacer**  
 (Extension) for 650-2-14A and F 2.9" (73.66mm) Cutterheads







**Miscellaneous Tooling for 650-2-14, 11100, and 11101 Cutterheads**

<p><b>501-29-6K PCD Tipped Triangular Insert</b>                  For Boring/                  Counterboring                  Aluminum Only -                  Ideal for Finishing                  Boring and                  Counterboring of                  Aluminum/Alusil                  Blocks in Preparation for a Sleeve.</p> 	<p><b>6598M Cartridge, Triangular</b>                  Positive Rake, 13/16" (20.650mm)                  Shank Length, for Counter Boring</p> 	<p><b>6598K Cartridge, Indexable Insert Assembly</b>                  1-7/8" (48mm) shank length for                  triangular positive rake inserts</p> 
<p><b>6598R Cartridge Assembly</b>                  Offset .250 (6.4mm)</p> 	<p><b>6599 Cartridge, Traingular, Zero Rake</b>                  1.88" (47.75mm) Long, for Steel                  Cutting, requires RTS inserts</p> 	<p><b>6599D Cartridge, Traingular, Zero Rake</b>                  1.88" (47.75mm) Long, insert offset                  down .250" (6.4mm) for blind holes, for                  Steel Cutting, requires RTS inserts</p> 
<p><b>6260L Cartridge Square Negative Rake</b>                  For Hi Speed Through Boring</p> 	<p><b>6260W Cartridge, Square, Negative Rake</b>                  Offset, for Cylinders with Clearance                  Problems.</p> 	<p><b>6513J Tool Bit</b>                  Brazed Carbide - .037" (.940mm)                  Wide O Ring Grooving</p> 

<p><b>6513L Tool Bit</b> Braze Carbide - .039" (.991mm) Wide O Ring Grooving</p> 	<p><b>6513N Tool Bit</b> Braze Carbide - .060" (1.524mm) Wide O Ring Grooving</p> 
<p><b>6513Q Tool Bit</b> Braze Carbide - .120" (3.048mm) Wide O Ring Grooving</p> 	<p><b>6513P Tool Bit</b> Braze Carbide - .085" (2.159mm) Wide O Ring Grooving</p> 
<p><b>6747K Cartridge Assembly - 5 Degree Chamfer</b> For Triangular Positive Rake Inserts</p> 	<p><b>6747P Cartridge Assembly - 10 Degree Chamfer</b> For Triangular Positive Rake Inserts</p> 
<p><b>6747G Cartridge Assembly - 15 Degree Chamfer</b> For Triangular Positive Rake Inserts</p> 	<p><b>6747F Cartridge Assembly - 20 Degree Chamfer</b> For Triangular Positive Rake Inserts</p> 
<p><b>6747M Cartridge Assembly - 20 Degree Chamfer</b> For Triangular Positive Rake Inserts (Special Application Only)</p> 	<p><b>6747H Cartridge Assembly - 30 Degree Chamfer</b> For Triangular Positive Rake Inserts</p> 

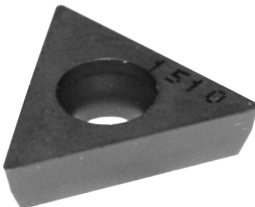

<p><b>6593L Cartridge Assembly</b> Offset Indexable Insert, Triangular Positive Rake, 3.14 - 3.40" (79.756 - 86.36mm) diameter</p> 	<p><b>6593M Cartridge Assembly</b> Offset Indexable Insert, Triangular Positive Rake, 3.40 - 3.90" (86.36 - 99.06mm) diameter</p> 
<p><b>6593N Cartridge Assembly</b> Offset Indexable Insert, Triangular Positive Rake, 3.90 - 4.40" (99.06 - 111.76mm) diameter</p> 	<p><b>6593P Cartridge Assembly</b> Offset Indexable Insert, Triangular Positive Rake, 4.40 - 4.90" (111.76 - 124.46mm) diameter</p> 
<p><b>RT211 Insert</b> Triangular 1/4" (6.35mm) 1/64" (.397mm) radius, 1/4" triangular Insert holders only, general purpose and sleeving (10% Discount on orders of 10-49, 20% Discount on orders of 50 or more)</p> 	<p><b>RT212 Insert</b> Triangular 1/4" (6.35mm) 1/32" (.787mm) radius, 1/4" triangular Insert holders only, general purpose and sleeving (10% Discount on orders of 10-49, 20% Discount on orders of 50 or more)</p> 
<p><b>RT321 Insert</b> Triangular positive rake, 3/8" (9.525mm) 1/64" (.397mm) radius, general purpose and sleeving (10% Discount on orders of 10-49, 20% Discount on orders of 50 or more)</p> 	<p><b>RT322 Insert</b> Triangular positive rake, 3/8" (9.525mm) 1/32" (.787mm) radius, general purpose and sleeving (10% Discount on orders of 10-49, 20% Discount on orders of 50 or more)</p> 

**RT321F Insert**

Triangular positive rake, 3/8" 1/64" Radius, Precision Counterboring (10% Discount on orders of 10-49, 20% Discount on orders of 50 or more)

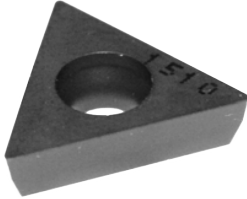

**RT322F Insert**

Triangular positive rake, 3/8" 1/32" Radius, Precision Counterboring (10% Discount on orders of 10-49, 20% Discount on orders of 50 or more)



**RTS321 Insert**

Triangular, 3/8" 1/64" Radius, General Purpose Steel Cutting, (10% Discount on orders of 10-49, 20% Discount on orders of 50 or more)



**RTS322Insert**

Triangular Positive Rake, 3/8" 1/32" Radius, General Purpose Steel Cutting (10% Discount on orders of 10-49, 20% Discount on orders of 50 or more)



**RS322 Insert**

Square negative rake, 1/32" (.787mm) radius, 3/8" (9.525mm) IC, black ceramic coated for high speed oversize through boring (10% Discount on orders of 10-49, 20% Discount on orders of 50 or more)

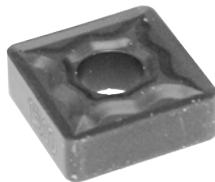

## Surfacing Tooling

### **650-2-8E Surfacing Cutterhead, Flycutter, 10" (254mm) Diameter**







Including (2) Radially and Axially Adjustable 3/8" (9.525mm) IC Insert Holders (Inserts Must be Ordered Separately)



### **650-2-8F Surfacing Cutterhead, Flycutter, 14" (356mm) Diameter**

Including (2) Radially and Axially Adjustable 3/8" (9.525mm) IC Insert Holders (Inserts Must be Ordered Separately)



<p><b>6303B CBN Insert</b>                  Round, Double-Sided, 3/8" (9.525mm) IC, for Cutting Cast Iron (15% Discount on orders of 10 or more)</p> 	<p><b>6303M Pcd Insert</b>                  Round, 3/8" (9.525mm) IC, for Cutting Aluminum (15% Discount on orders of 10 or more)</p> 	<p><b>6303K Coated Carbide Insert</b>                  Round, 3/8" (9.525mm) IC, for General Purpose Use</p> 
<p><b>6303S CBN Insert</b>                  Round, 3/8" (9.525mm) IC, for Cutting Aluminum Blocks with Liners (15% Discount on orders of 10 or more)</p> 	<p><b>6303U CBN Round Insert</b>                  Single Sided, 3/8" IC. For hard cast iron (15% Discount on orders of 10 or more)</p> 	<p><b>6303V CBN Insert, Octagonal</b>                  (16-Cutting Corners) for surfacing large diesel blocks (15% Discount on orders of 10 or more)</p> 



## Surfacing Fixtures

### 7209M Leveling Table with Airfloat

Complete with Universal Work Holding System for Surfacing Cylinder Heads and Small In-Line Blocks

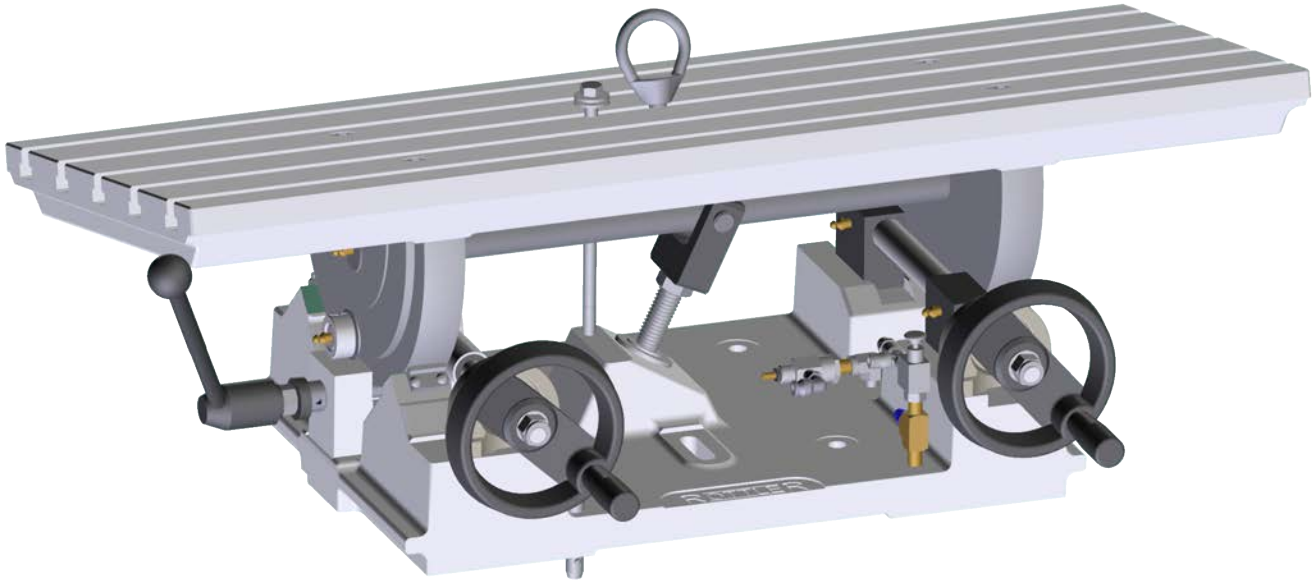
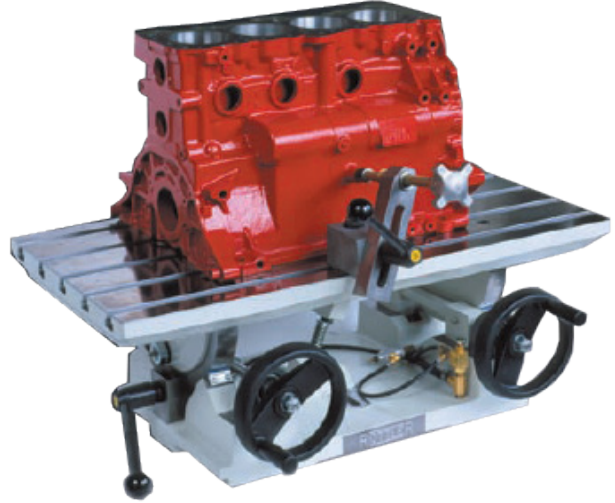

**7209N 2-Piece Vise**

For Surfacing Main Bearing Housing Caps in Preparation for Main Line Boring. Also used for Holding Exhaust Manifolds for Surfacing. Requires 7209M Leveling Table.

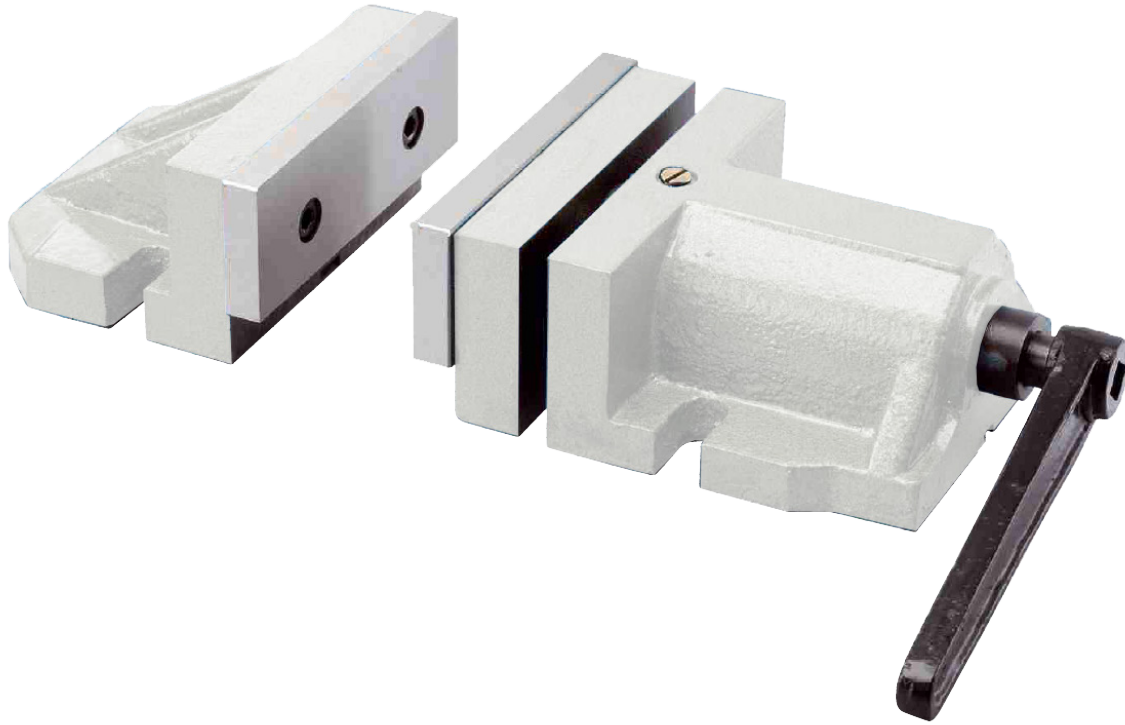

**7152A Dual Axis Level Assembly**



## Main Line Bore Tooling

### 11103E Main Line Bore 90 Degree Right Angle Drive Assembly

2" Extended, Diameter 1.9 - 5.6" (48 - 142.2mm) Minimum clearance 3.29" (83.6mm) with 650-2-39B Cutterhead, Includes 5 extensions spacers

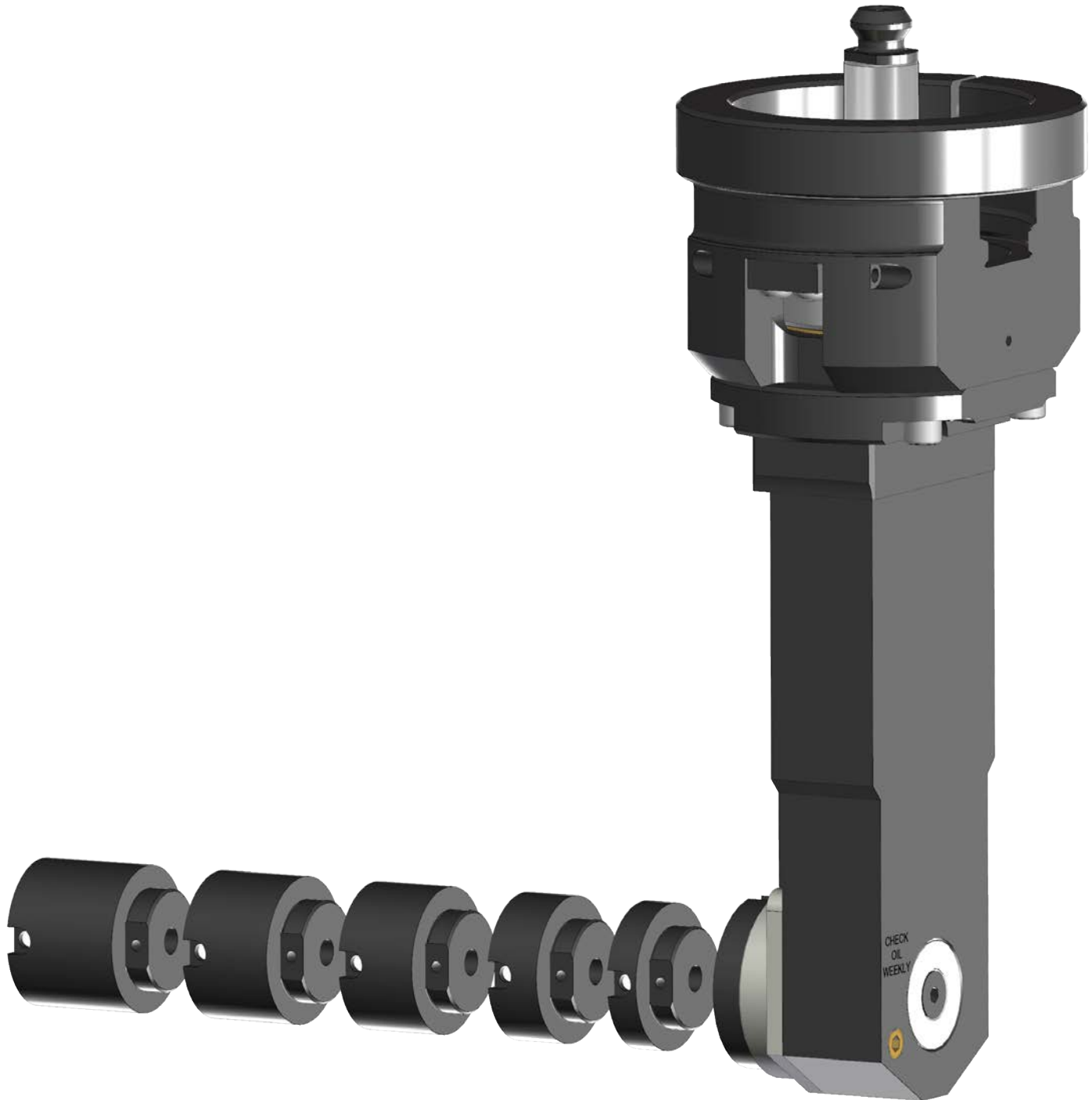

**11104 Special Belt Drive 90 Degree Right Angle Drive Assembly**

For Limited Clearance Between Bearing Caps, Diameter 1.9 - 4.0" (48 - 101.6mm) Minimum clearance 2.7" (69mm) with 650-2-39B Cutterhead, includes 5 extension spacers



**11105 Narrow Right Angle Drive 1.9 - 2.4" (48 - 60.9mm)**

Note: Cutterheads are not included with right angle drive and must be ordered separately

Note: The Belt Drive Right Angle Drive is Designed for Limited Clearance Between Bearing Caps and It's Cutting Performance Will Deteriorate as Larger Diameters are Bored and Extension Spacers are Used.

Note: Length of Bores can be Increased with Extension Spacers. The Addition of Extension Spacers Will Increase The Minimum Distance Between Bearing Housings by the Length of the Spacer. Allow for some Clearance either side of the Assembly for Safety While

Rottler Right Angle Drive Line Bore System will not be able to Line Bore Blocks that have Castings Between the Main Bearing Caps Found in Some New Design Light Weight Blocks.

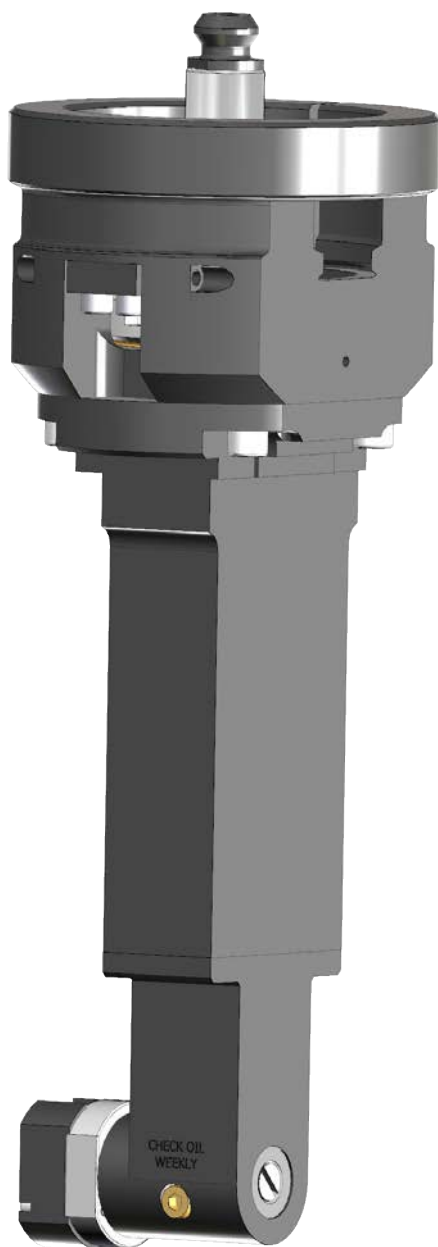



**650-2-39B Cutterhead Package Line Boring 1.9 - 4.0" (48.26 - 101.60mm) Diameter**

Complete with Tooling and Digital Micrometer. (When used with 11103 Drive, minimum distance between Bearing Housings 3.29") (83.6mm)









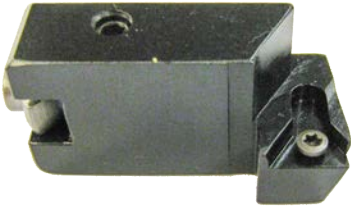

**650-2-39C Cutterhead Package Line Boring 2.9 - 5.6" (73.66 - 142.24mm) Diameter**

Complete with Tooling and Digital Micrometer. When used with 11103 Drive, minimum distance between Bearing Housings 4.07" (103.4mm)







**Tooling For Cutterheads 650-2-39B & 650-2-39C**

<p><b>6801B Tool holder Assembly</b>                  Indexable Insert 1/4" Triangle, Positive Rake, 1.44"                  (36.576mm) Overall Length</p> 	<p><b>6801C Tool holder Assembly, Indexable</b>                  Insert 3/8" Triangle, Positive Rake, 1.65" (41.91mm)                  Overall Length</p> 
<p><b>6801D Tool holder Assembly</b>                  Indexable Insert 3/8" Triangle, Positive Rake, 1.85"                  (46.99mm) Overall Length</p> 	<p><b>6801E Tool holder Assembly</b>                  Indexable Insert 3/8" Triangle, Positive Rake, 2.05"                  (52.07mm) Overall Length</p> 
<p><b>6801F Tool holder Assembly</b>                  Indexable Insert 3/8" Triangle, Positive Rake, 2.25"                  (57.15mm) Overall Length</p> 	<p><b>6801G Tool holder Assembly</b>                  Indexable Insert 3/8" Triangle, Positive Rake, 2.45"                  (62.23mm) Overall Length</p> 
<p><b>6801H Tool holder Assembly</b>                  Indexable Insert 3/8" Triangle, Positive Rake, 2.65"                  (67.31mm) Overall Length</p> 	<p><b>6801J Tool holder Assembly</b>                  Indexable Insert 3/8" Triangle, Positive Rake, 2.85"                  (72.39mm) Overall Length</p> 

**Special Main Line Boring Thrust Facing Tooling**

<p><b>6801M Tool Holder</b> Indexable Insert, Thrust Facing .160 IC, Positive Rake</p> 	<p><b>6801P Tool Holder Package</b> Indexable Insert, Thrust Facing 350 Chevy and other small blocks line boring</p> 	<p><b>501-29-6G Insert, Triangular</b> .160 IC 1/64" (.397mm) Radius</p> 
<p><b>501-29-6J Insert</b> Triangular, .160 IC 1/32" (.787mm) Radius</p> 	<p><b>501-29-6H Insert Screw</b></p> 	

**Special Main Line Boring Chamfering Tooling**

<p><b>199-90 Tool Holder</b> 2 - 3" (50.80 - 76.20mm)</p> 	<p><b>199-96 Tool Holder</b> 3 - 4" (76.20 - 101.60mm)</p> 	<p><b>501-33E Tool Bit</b> 45 Degree Chamfer</p> 
---	--	--

## Equipment for Centering In Bores

### 502-12-4A Magnetic Indicator Holder Assembly (Requires 502-9-9A Mechanical Runout Indicator)

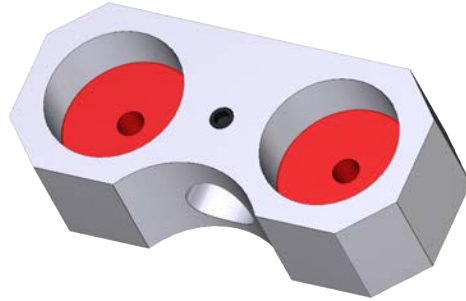

### 502-9-9A Mechanical Run Out Indicator General Purpose (.001 Resolution)



### 502-12-4 Magnetic Base Including (2) Extension Arms for Indicators

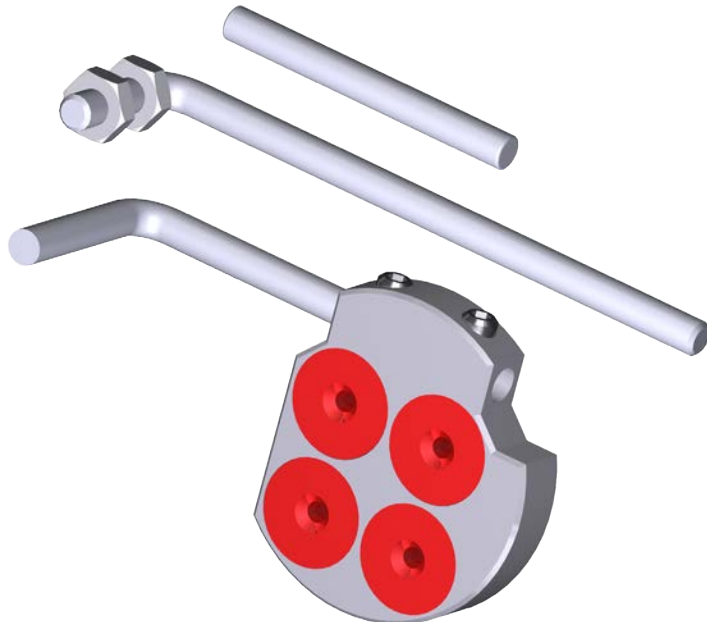

## Cam Line Boring Tooling

### 650-3-43T Cam Line Bore Tooling Package

(Requires 650-3-30 Block End Truing Fixture, 650-3-1 Performance Fixture and 6753Q Right Angle Drive Assembly)  
Customer Must Order Cam Line Bar Bushings and Cam Bearing Locators to Suit Diameter to be Line Bored. Includes the following items:

650-2-3R	Stub Bar Assembly 1.9 - 2.3" (48.26 - 58.42mm) diameter
650-3-43	Support, Locator-Cam Line Boring (Customer Must Choose the Cam Bearing Locators they Require from the Listing of 650-3-19 Series Cam Bearing Locators - two are Required for Use with Support)
650-2-32	Block Clamp Arm Cam Line Boring (two Each Are Required) Cost for Each:
650-2-32A	Stud, Block Clamp Arm Cam Line Boring (two Are Required) Cost for Each:
650-2-19G	Adapter and Dual Flex Coupling Assembly Cam Line Boring
650-2-32D	Bar, Cam Line Boring 1-3/4" X 45" (44.45 X 1143.00mm) Long
650-2-32E	Cartridge, Indexable Insert Cam Line Boring, 1.530" (38.862mm) Long, Range 1.985 - 2.650" (50.419 - 67.310mm) diameter. Two included in Assembly. Cost for Each:
650-2-32F	Cartridge, Indexable Insert Cam Line Boring, 1.650" (41.91mm) Long, Range 2.250 - 2.850" (57.150 - 72.390mm) diameter. One included in Assembly. Cost for Each:
650-2-32G	Wrench, Tool bit Adjusting Cam Line Boring (3mm)
650-2-32H	Wrench, Tool bit Lockscrew Cam Line Boring (2.5mm)
650-2-32J	Wrench, Tool bit Insert Screw Cam Line Boring T-6
650-2-32L	Insert, Cam Line Boring (Three Each Included In Assembly) Cost for Each:
650-2-32M	Screw, Insert Cam Line Boring (Three Each Included In Assembly) Cost for Each:
650-2-33	Indicator, Tool Setting With Magnetic Base Cam Line Boring
650-2-32K	Tool Bit, Oil Groove Cam Line Boring
199-96	Tool Holder, 1-1/4" (31.75mm) Or Choose Holder Required From 199- Series Tool Holders
650-2-3Q	Stub Bar Assembly. 1.9 - 2.3" (48.26 - 58.42mm) diameter with Standard Tooling. 1.9 - 2.7" (48.26 - 68.58mm) With Optional Tool holder
6802B	Tool Holder Assembly, Indexable Insert 1/4" (6.35mm) Triangle, Positive Rake 1.9 - 2.3" (48.26 - 58.42mm) Diameter. Cam Line Bore Cutterhead Only
6802C	Tool Holder Assembly, 3/8" (9.525mm) Triangular Positive Rake 2.3 - 2.7" (58.42 - 68.58mm) diameter. (Optional) Note: Requires 3/8" (9.525mm) Insert, RT321 or RT322
900-2-19	Universal Micrometer Assembly Digital Reading (Inch and Metric) for 1/2" tooling
501-72A	Hex Driver, 5/32" (3.962mm)
T8D	Torx Wrench, Triangular Insert Cartridge Tool holders. 1/4" (6.35mm) Triangle Insert Holders Only
RT211	Insert, Triangular 1/4" (6.35mm) 1/64 Radius (1/4 Triangle Insert Holders Only) General Purpose and Sleaving
RT212	Insert, Triangular 1/4" (6.35mm) 1/32 Radius (1/4 Triangle Insert Holders Only) General Purpose and Sleaving





### Cam Line Bar Bushings

If Customer Requires Sizes Other Than Listed Following, Rottler Will Manufacture the Required Size. Customer Must Provide the Size, Including Tolerance, of the Housing Bore/s the Bushing will be used in. Rottler will use this Information to Design the Actual Bushing. (Sold In Pairs) Bushings are Machined Smaller than Housing Bore.

<p><b>650-3-43B Bushing - 62.992mm (2.480" +/- .0007)</b> (Sold in pairs)</p>	<p><b>650-3-43C Bushing - 57.963mm (2.282" +/- .0007)</b> (Sold in pairs)</p>
<p><b>650-3-43D Bushing - 57.150mm (2.250" +/- .0007)</b> (Sold in pairs)</p>	<p><b>650-3-43E Bushing - 70.866mm (2.790" +/- .0007)</b> (Sold in pairs)</p>
<p><b>650-3-43F Bushing - 58.649mm (2.309" +/- .0007)</b> (Sold in pairs)</p>	<p><b>650-3-43G Bushing - 63.500mm (2.500" +/- .0007)</b> (Sold in pairs)</p>



**650-3-43H Bushing - 53.848mm (2.120" +/- .0007)**  
 (Sold in pairs)

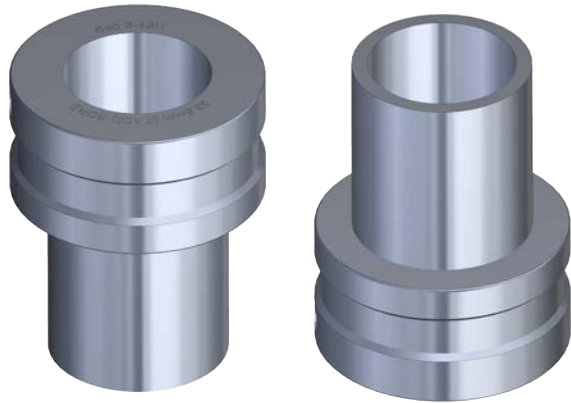

**650-3-43J Bushing - 51.562mm (2.030" +/- .0007)**  
 (Sold in pairs)

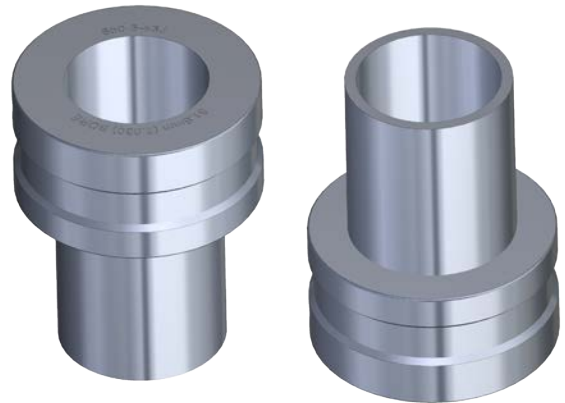

**650-3-43K Bushing - 51.816mm (2.040" +/- .0015)**  
 (Sold in pairs)

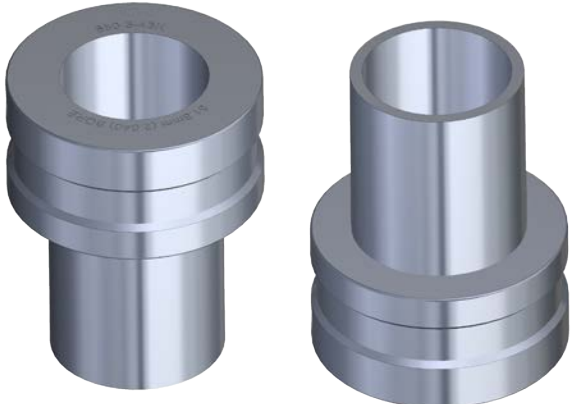

**650-3-43L Bushing - 60.960mm (2.400" +/- .0007)**  
 (Sold in pairs)



**650-3-43M Bushing - 53.975mm (2.125" +/- .0007)**  
 (Sold in pairs)



**650-3-43N Bushing - 54.610mm (2.150" +/- .0007)**  
 (Sold in pairs)

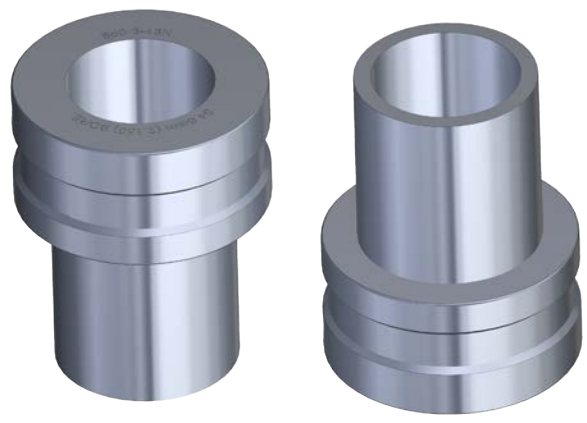

**650-3-43P Bushing - 58.420mm (2.300" +/- .0007)**  
 (Sold in pairs)

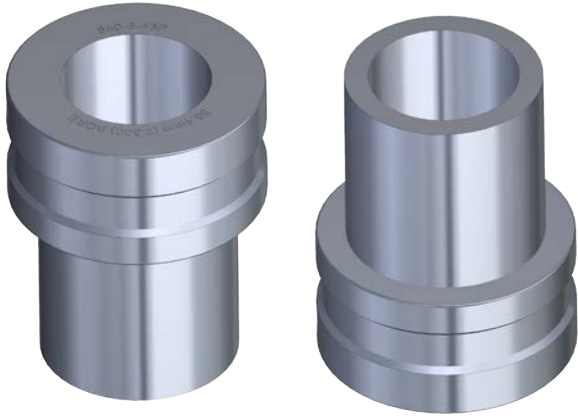

**650-3-43Q Bushing - 52.324mm (2.060" +/- .0007)**  
 (Sold in pairs)

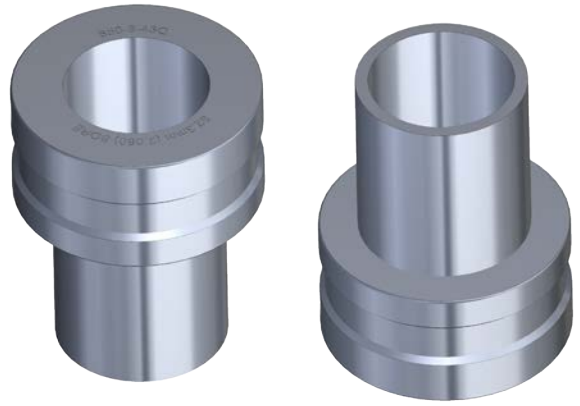

**650-3-43R Bushing - 67.902mm (2.6733" +/- .0007)**  
 (Sold in pairs)



**650-3-43S Bushing - 51.943mm (2.0450 +/- .0007)**  
 (Sold in pairs)

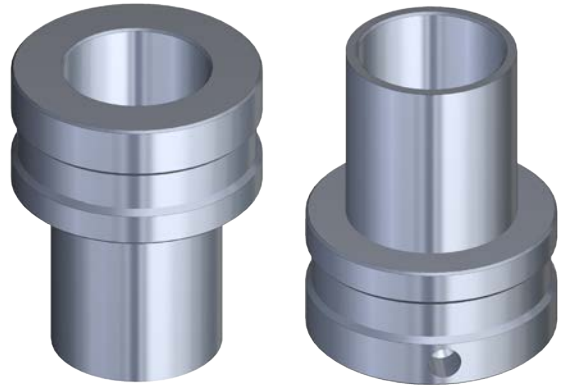

## Lifter Bore Tooling

### 650-2-60B Lifter Bore Tooling Kit

For F69A only



**650-2-20C End mill**

Special .980" (24.892mm) diameter X 8-1/2" (215.9mm) long. Four flutes. 1" (25.4mm) shank (Chevy)



**650-2-20L End mill**

Center cutting 1-1/8" (28.545mm) diameter X 6-1/2" (165.1mm) long. Six flutes. 1" (25.4mm) shank (Chevy & Ford)



**T8D Torx Wrench**

1/4" (6.35mm) Triangular Insert Holder



**650-2-60M T5 Torx Wrench**



**650-2-44A End Mill Adapter**

1" (25.4mm) Complete with 650-2-44L Retention Knob CAT 40 Taper



**650-2-44L CAT 40 Retention knob**



**650-2-60C Boring Bar**

0.750 - 0.900" (19.05 - 22.86mm) diameter



**650-2-60E Cartridge with dial assembly**

0.750 - 0.900 diameter



**650-2-60G Insert for 0.750 - 0.900 diameter cartridge**



**650-2-60J Wrench**

For 0.750 - 0.900 diameter cartridge



**650-2-60D Boring Bar**  
 0.920 - 1.180" (23.36 - 29.97mm) diameter



**650-2-60F Cartridge only**  
 0.920 - 1.180 diameter



**650-2-60H Insert**  
 For 0.920 - 1.180 diameter cartridge



**650-2-60K Wrench**  
 For 0.920 - 1.180 diameter cartridge



**650-2-60L Hardware kit**  
 (including dial and mounting screws) for 650-2-60F cartridge





### Lifter Bore Bushing Installation Tooling

**11117A 31mm Lifter Sleeve Press Tool**  
Requires CAT 40 Adapter 1"

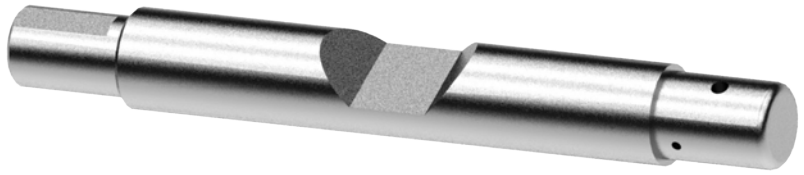

**11117B 26.9mm Lifter Sleeve Press Tool**  
Requires CAT 40 Adapter 1"

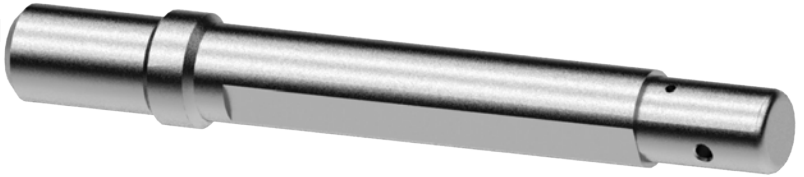

### Spacers Required for the Performance Fixture #650-3-1

To set V blocks at the correct angle for lifter boring machine work

<p><b>650-3-7E 4-Degree Cam Bar Spacer</b> Chev. Small Block Only</p>  <p>S/B CHEV</p>	<p><b>650-3-7F 6.25 Degree Cam Bar Spacer</b> Chev. Big Block Only</p>  <p>S/B CHEV</p>	<p><b>650-3-7G Spacer, Cam Bar 3.5 Degree</b> Ford 289/302/351W</p>  <p>FORD 351W 289/302</p>
---	--	--



**650-3-7H Spacer, Cam Bar 4-Degree**  
Ford 429/400



**650-3-7J Spacer Cam Bar 48-Degree**  
Mopar Small Block (Race)



**650-3-7N Spacer, Cam Bar 42-Degree**  
Chevy Aurora



**650-3-7P Spacer, Cam Bar 43-Degree**  
Chevy Aurora



**650-3-7Q Spacer, Cam Bar 44-Degree**  
Chevy Aurora



**650-3-7S Spacer, Cam Bar 44-Degree**  
Chevy Small Block





**650-3-7T Spacer, Cam Bar 48-Degree**  
Chrysler Big Block



### Complete Listing Of CAT 40 Taper End Mill Holders

<p><b>650-2-44J Adaptor 1/2" (12.70mm)</b></p> 	<p><b>650-2-44S Adaptor 5/8" (15.875mm)</b></p> 
<p><b>650-2-44C Adaptor 3/4" (19.05mm)</b></p> 	<p><b>650-2-44B Adaptor 7/8" (22.225mm)</b></p> 
<p><b>650-2-44A Adaptor 1" (25.40mm)</b></p> 	<p><b>650-2-44K Adaptor 1-1/4" (31.75mm)</b></p> 

## Thread Tapping Tooling

<p><b>650-2-11K Quick Change Tap Holder Cartridge Assembly with Adaptor</b></p> 	<p><b>650-2-11B Quick Change Straight Shank Tap Holder Cartridge</b></p> 
---	---

## Torque Control Tap Holders

For 650-2-11B Straight Shank Tap Holder Cartridge

<p><b>650-2-11C Torque Control Tap Holder</b> For 1/4" (6.35mm) Taps</p> 	<p><b>650-2-11D Torque Control Tap Holder</b> For 5/16" (7.95mm) Taps</p> 	<p><b>650-2-11E Torque Control Tap Holder</b> For 3/8" (9.525mm) Taps</p> 
<p><b>650-2-11F Torque Control Tap Holder</b> For 7/16" (11.13mm) Taps</p> 	<p><b>650-2-11G Torque Control Tap Holder</b> For 1/2" (12.70mm) Taps</p> 	

## Drill Tooling



650-2-44M Precision Drill Chuck Assembly

650-2-9A Drill Chuck Adaptor



650-2-9B Drill Chuck 1/8-5/8" (3.175-15.875mm) With Key

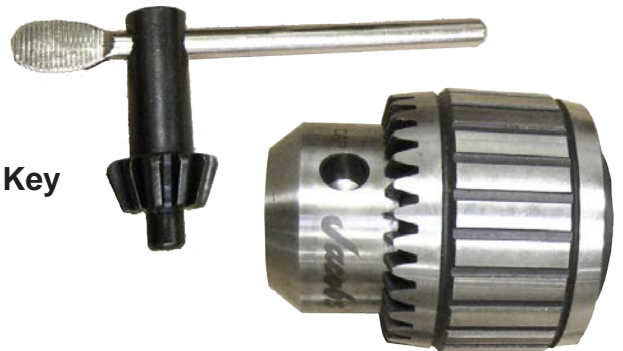

**650-2-44N 2 1/2" (63.50mm)  
Shell Mill Assembly**



**650-2-44G Shell Mill Holder**



**7224E 2 1/2" (63.50mm) Shell Mill**



**6514T Cutting Inserts**  
For 2-1/2" (63.50mm) Shell Mill (Six  
Required)

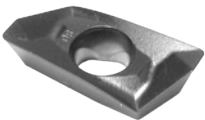

**7224D Socket Head Cap Screw**  
3/8-24Nf X 1"



**650-2-44L CAT 40 Retention knob**





**650-2-44P 4" (101.60mm) Shell Mill Assembly**



**650-2-44F Shell Mill Holder**



**7224F 4" (101.60mm) Shell Mill**

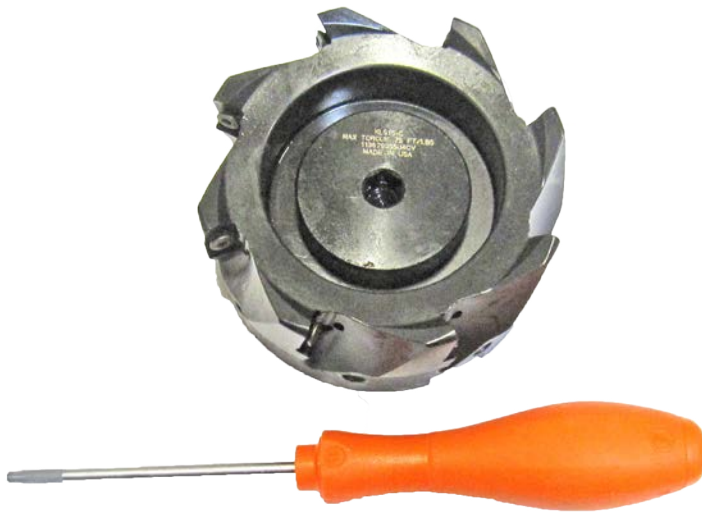

**6514T Cutting Inserts**  
For 4" (101.60mm) Shell Mill (Eight Required)



**650-2-26B Mounting Bolt**



**650-2-44L CAT 40 Retention knob**





## **650-2-44W Block Lightening Tooling Package for Dart Small Block Chev**

Includes the following items:

- (2) 650-2-44A End Mill Adapter 1" (25.4mm) Complete With 650-2-44L Retention Knob CAT 40 Taper F69A
- (1) 650-2-44V 1" (25.4mm) Four Fluted End Mill X 4" (101.6mm) Overall Length-Block Lightening Tooling Package
- (1) 650-2-45C Indexable Tool holder Mill 1" (25.4mm) Block Lightening Tooling Package
- (10) 650-2-45D Inserts for 1" (25.4mm) Indexable Tool holder mill - Block Lightening Tooling Package
- (1) 650-2-44K End Mill Adapter 1 1/4" (31.75mm) Complete with 650-2-44L Retention Knob CAT 40 Taper F69A
- (1) 650-2-45A Indexable Tool holder Mill 1 1/2" (38.1mm) Block Lightening Tooling Package
- (10) 650-2-45B Inserts for 1 1/2" (38.1mm) Indexable Tool holder Mill -Block Lightening Tooling Package
- (3) 650-2-44S End Mill Adapter 5/8" (15.875mm) Complete with 650-2-44L Retention Knob CAT 40 Taper
- (1) 650-2-44T 5/8" (15.875mm) Four Fluted End Mill X 6.00" (152.4mm) Overall Length. Block Lightening Tooling Package
- (2) 650-2-44U 5/8" (15.875mm) Four Fluted End Mill X 3.50" (88.9mm) Overall Length. Block Lightening Tooling Package
- (2) 650-3-14R Locator-Cam Chevy CNC Bow-Tie Block All Cam Bores 1.9990/2.0010 Diameter
- (1) 650-3-69 Locator, Main#5, 2.6406 - 2.6421" (67.07 - 67.11mm) bore, 4th Axis Fixture
- (1) 650-3-87A Block Pacer Block Lightening Package



**650-2-44X Block Lightening Tooling Package for World Products Small Block Chev**

Includes the following items:

- (1) 650-2-44Z Software Package - Rottler Complete Block Lightening Program for World Blocks
- (2) 650-2-44A End Mill Adapter 1" (25.4mm) Complete With 650-2-44L Retention Knob CAT 40 Taper F69A
- (1) 650-2-44V 1" (25.4mm) Four Fluted End Mill X 4" (101.6mm) Overall Length-Block Lightening Tooling Package
- (1) 650-2-45C Indexable Tool holder Mill 1" (25.4mm) Block Lightening Tooling Package
- (10) 650-2-45D Inserts for 1" (25.4mm) Indexable Tool holder mill - Block Lightening Tooling Package
- (1) 650-2-44K End Mill Adapter 1 1/4" (31.75mm) Complete with 650-2-44L Retention Knob CAT 40 Taper F69A
- (1) 650-2-45A Indexable Tool holder Mill 1 1/2" (38.1mm) Block Lightening Tooling Package
- (10) 650-2-45B Inserts for 1 1/2" (38.1mm) Indexable Tool holder Mill -Block Lightening Tooling Package
- (3) 650-2-44S End Mill Adapter 5/8" (15.875mm) Complete with 650-2-44L Retention Knob CAT 40 Taper
- (1) 650-2-44T 5/8" (15.875mm) Four Fluted End Mill X 6.00" (152.4mm) Overall Length. Block Lightening Tooling Package
- (2) 650-2-44U 5/8" (15.875mm) Four Fluted End Mill X 3.50" (88.9mm) Overall Length. Block Lightening Tooling Package
- (1) 650-3-14 Locator-CAM Small Block Chevy Known Applications: Chevy 283/327/350/400 X5 CAM Bore 2.0090/2.0110" (51.029/51.079mm) Diameter
- (1) 650-3-14G Locator-CAM Small Block Chevy Known Applications: Chevy 283/327/350/400 X5 CAM Bore 2.0190/2.0210" (51.626/51.333mm) Diameter
- (1) 650-3-69 Locator, Main#5, 2.6406 - 2.6421" (67.07 - 67.11mm) bore, 4th Axis Fixture
- (1) 650-3-87A Block Pacer Block Lightening Package



## 650-2-45J Block Lightening Tooling Package for Big Block Chevy

Includes the following items:

- (1) 650-3-87A Block Pacer-Block Lightening Package
- (2) 650-2-44A End Mill Adapter 1" (25.4mm) Complete With 650-2-44L Retention Knob CAT 40 Taper F69A
- (1) 650-2-44K End Mill Adapter 1 1/4" (31.75mm) Complete with 650-2-44L Retention Knob CAT 40 Taper F69A
- (1) 650-2-45A Indexable Tool holder Mill 1 1/2" (38.1mm) Block Lightening Tooling Package
- (10) 650-2-45B Inserts for 1 1/2" (38.1mm) Indexable Tool holder Mill -Block Lightening Tooling Package
- (1) 650-2-45C Indexable Tool holder Mill 1" (25.4mm) Block Lightening Tooling Package
- (10) 650-2-45D Inserts for 1" (25.4mm) Indexable Tool holder mill - Block Lightening Tooling Package
- (1) 650-2-45L Indexable Tool holder Mil 1" (25.4mm) Block Lightening Tooling Package
- (10) 650-2-45M Indexable Milling Insert for 650-2-45L Tool Holder Mill, Block Lightening Tooling Package
- (10) 650-2-45N Indexable Milling Insert for 650-2-45L Tool Holder Mill, Block Lightening Tooling Package
- (2) 650-3-14P Locator - CAM Chevy CNC Bow, Tie Block all CAM Bores 2.1200/2.1210" (53.848/53.873mm)
- (1) 650-3-69B Locator, Main #5, 2.9380 - 29395" (74.63 - 74.66mm) bore





**650-2-45Q Big Block Main Cap Lightening Fixture Assembly with Tooling**

Includes the following items:

- (1) 650-2-45U Indexable Ball Nose Endmill - Main Bearing Cap Lightening
- (10) 650-2-45V Carbide Inserts - Ball Nose Enmill - Main Bearing Cap Lightening
- (4) 650-2-45W Button Head Screw, 1/2-13 X 3" (12.7-330.2 X 76.2mm) Long - Main Bearing Cap Lightening Fixture
- (1) 650-2-45R Fixture - Main Bearing Cap Lightening
- (2) MF-202 Dowel Pins 1/4 X 1/2" (6.35 X 12.7mm)
- (1) MF-12 Socket Head Capscrew 1/4-20 X 1/2" (6.35-508 X 12.7mm)
- (2) MF-15 Socket Head Capscrew 1/4-20 X 1" (6.35-500 X 25.4mm)
- (1) MF-82 Socket Head Capscrew 3/8-16 X 3/4" (9.525-406.4 X 19.05mm)
- (1) 650-2-45X Driver, Rear Main - Main Bearing Cap Lightening
- (1) 650-2-45T Locator, Rear Main - Main Bearing Cap Lightening
- (1) 650-2-45S Spacer Plate, Rear Main - Main Bearing Cap Lightening

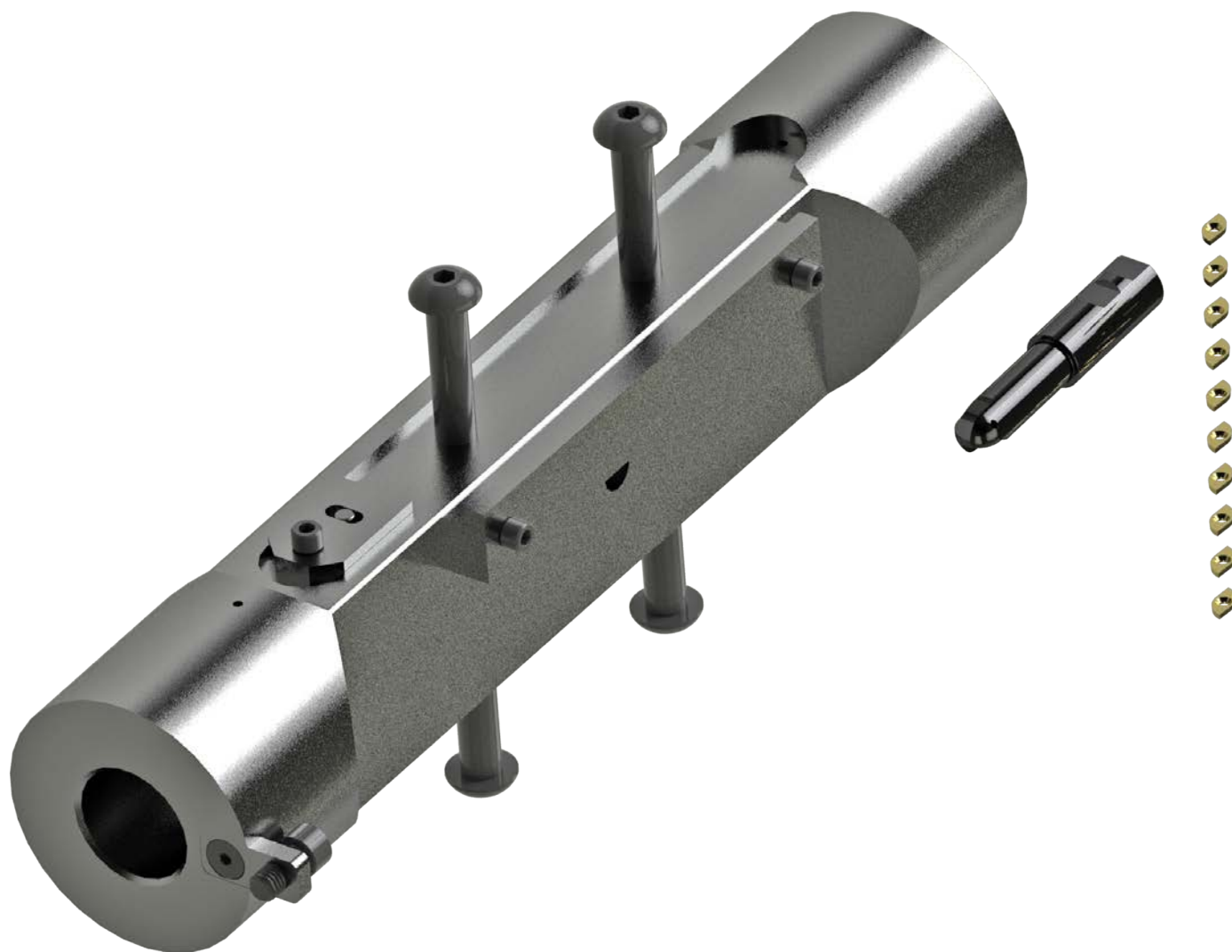



## Connecting Rod Fixturing And Tooling

### 650-3-44S Rottler Precision Connecting Rod Fixturing System

For Connecting Rods Center to Center Distance Approx 8 - 24" (200 - 600mm)



**650-2-3S Cutterhead Package**

1.0 - 2.0" (25 - 50mm) Diameter X 3.0" (75mm) Long Complete with Tooling and Digital Micrometer for Con Rod Application

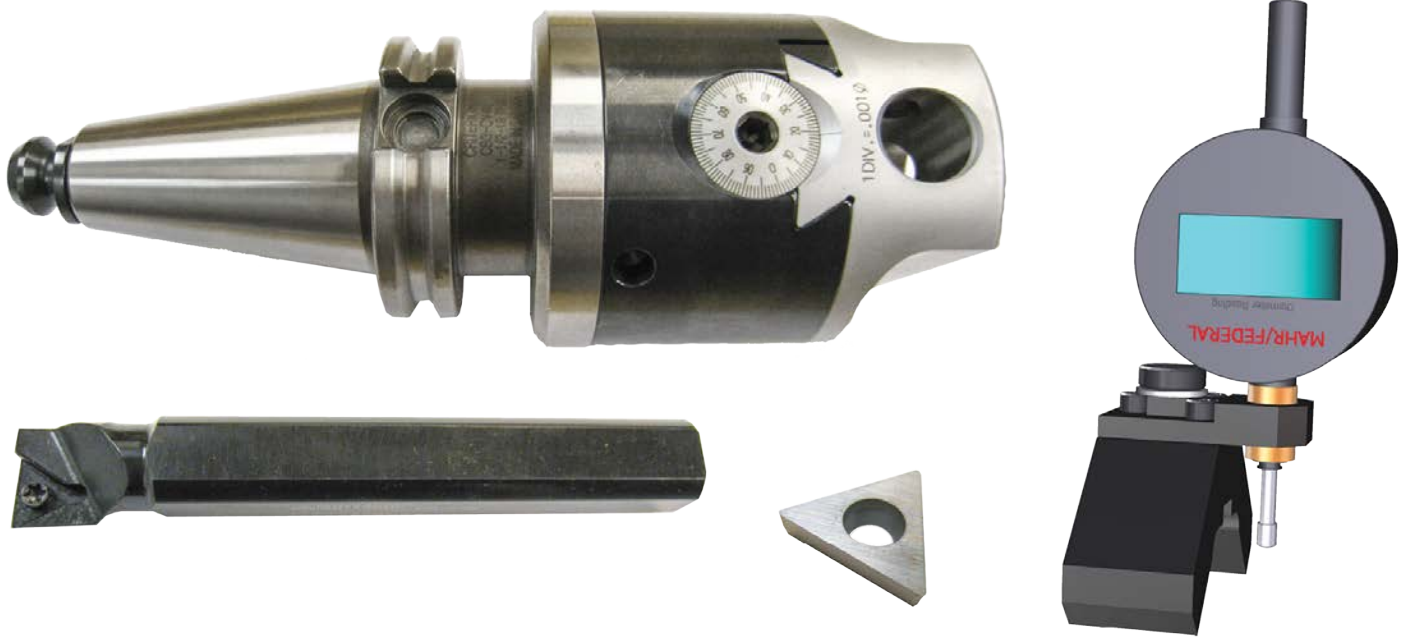

**650-2-3T Cutterhead Package**

2.0 - 4.0" (50 - 100mm) Diameter X 4.0" (100mm) Long Complete with Tooling and Digital Micrometer for Con Rod Application.



**650-2-15F Cutterhead Package**

2.9 - 8.0" (73.5 - 200mm) Diameter X 4.0" (100mm) Long Complete with Tooling and Digital Micrometer for Con Rod Application.



**RTCR322 Insert, Triangular Positive Rake, 3/8 IC 1/64" (9.397mm) Radius**

For Connecting Rod Steel Cutting Only

