

ROTTLER

SG10A OPTIONAL EQUIPMENT CATALOG

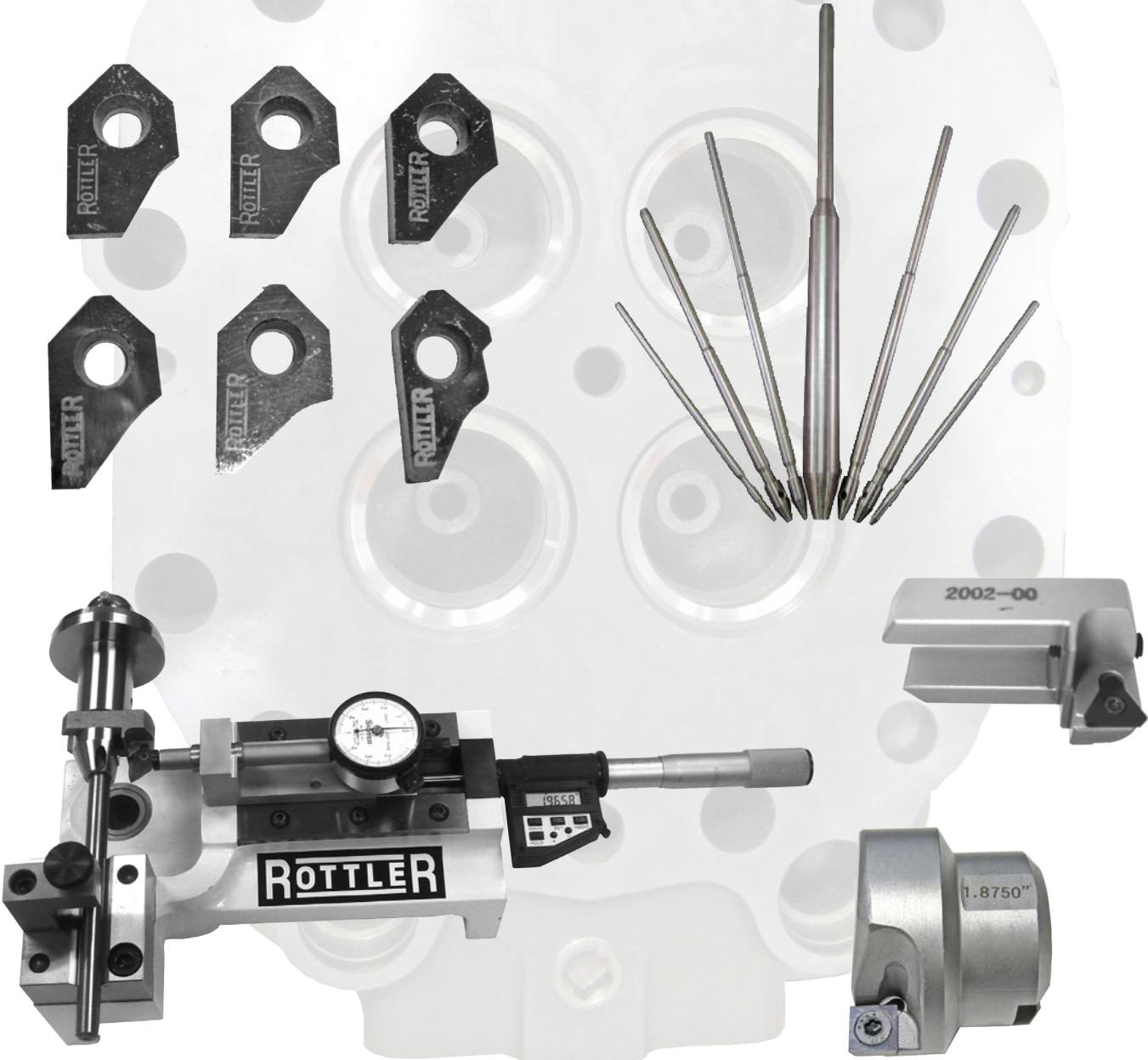

ORDERING PROCEDURE

Contact your regional Rottler sales rep for assistance in ordering optional equipment, replacement parts, or tooling.

If you are unable to contact your regional Rottler sales rep, call the factory at 253-872-7050 and ask to speak to the parts sales specialist.

Have the following information handy to expedite the ordering process:

1. Your name, business name, and contact number
2. Customer number
3. If you don't have a customer number, your billing address
4. Shipping address if different from billing address
5. Machine model and serial number
6. Part number and description of what you want to order
7. Preferred method of shipment

You may also contact us via e-mail with the above information. Send e-mail requests to:
parts@rottermfg.com

In some cases you may be requested to send a photo of the part you are ordering if it is a replacement part, or doesn't appear in the database.

If you are unsure which part you need to order, contact our service department and ask to speak to one of our service consultants. They will assist you in determining which part you require.

THERE IS A MINIMUM ORDER OF \$25.00



Contents

Rottler UNIPILOT Spindle Adapters and Tool Holders.....	1
UPT5200 Rottler (Patent Pending) Unipilot Tool Holder	1
UPT5400 Rottler (Patent Pending) Unipilot Tool holder	1
Rottler R1 Taper Tool Holders	1
UPTRS105 Rottler R1 Spindle Taper Milling Head Driver	1
RS105 Rottler R1 Spindle Taper Milling Head Driver	1
RS560 Rottler R1 Spindle Taper Milling Head Driver	2
SAD500R1 Spindle Adapter.....	2
SAD375R1 Spindle Adapter.....	2
PC375R1 Universal Three Jaw Chuck	2
COLLET-KITR1.....	3
R1MT3 Adapter for Morse #3 to Rottler R1 taper	3
Tip Holders for Valve Seat Angle Cutting.....	4
TH1999 Tip Holder	4
TH2000 Tip Holder	4
TH2001 Tip Holder	4
TH2002 Tip Holder	4
TH2003 Tip Holder	5
TH2004 Tip Holder	5
TH2005 Tip Holder	5
Suggested Basic Tooling.....	6
PRW375 Pilot Removal Wrench	6
PRW600 Pilot Removable Wrench	6
T8D T8 Torx Tip Holding Screw Driver	6
T7D T7 Torx Driver.....	6
ALLEN-KEYS-IN.....	6
ALLEN-KEYS-MM	6
Micrometers Setting Fixtures and Measurement Tools	7
DSP Tool setting Device with Interchangeable Point.....	7
BM Boring Micrometer, Digital Reading Inch and Metric.....	7
6-1SETTINGFIX	8
VSG102-375 Precision Valve Seat Concentricity Gage Base Only	8
VSG102-6MM Precision Valve Seat Concentricity Gage Base Only	9
502-11-39L Mechanical Run Out Indicator	9

502-11-39D Mechanical run out indicator.....	9
Special Fixtures, Clamps and Parallels.....	10
DIESELFIX Diesel Fixture	10
7242T Low Profile Clamp Tower Assembly.....	11
CANTEDFIX Canted Fixture.....	11
7618 Large Cylinder Head Clamping Fixture	12
Triangular Insert Tip Holders.....	13
TH2000-00 00 Degree Triangular Tip Holder	13
TH2001-00 00 Degree Triangular Tip Holder	13
TH2002-00 00 Degree Triangular Tip Holder	13
TH2003-00 00 Degree Triangular Tip Holder	13
TH2004-00 00 Degree Triangular Tip Holder	14
TH2005-00 00 Degree Triangular Tip Holder	14
Triangular Insert Holders	14
TH2002-30 30 Degree Triangular Tip Holder	14
TH2002-45 45 Degree Triangular Tip Holder	14
TH2003-20 20 Degree Triangular Tip Holder	15
TH2003-30 30 Degree Triangular Tip Holder	15
TH2003-45 45 Degree Triangular Tip Holder	15
TH2004-20 20 Degree Triangular Tip Holder	15
TH2004-30 30 Degree Triangular Tip Holder	16
TH2004-45 45 Degree Triangular Tip Holder	16
TH2005-20 20 Degree Triangular Tip Holder	16
TH2005-30 30 Degree Triangular Tip Holder	16
TH2005-45 45 Degree Triangular Tip Holder	17
Triangular Inserts and Torx Driver for the Previous Insert Holders	17
RT211 Triangular Insert.....	17
RT212 Triangular Insert.....	17
T7D T7 Torx Driver.....	17
CUTTING INSERTS	18
Cutting Insert Sharpener for Multi Angle Inserts	18
BWS02 Diamond Wheel Cutting Bit Sharpener - Single Wheel	18
Rottler Profile Cutter Inserts	19
Automotive Import, Domestic and Diesel Inserts.....	19
Suggested 45 Degree Seat Inserts.....	19
RCA001 Carbide Seat Insert.....	19



RCA004 Carbide Seat Insert	19
RCA005 Carbide Seat Insert	19
RCA007 Carbide Seat Insert	19
RCA014 Carbide Seat Insert	19
RCA026 Carbide Seat Insert	19
Suggested 30 Degree Seat Inserts	20
RCA301 Carbide Seat Insert	20
RCA303 Carbide Seat Insert	20
RCA307 Carbide Seat Insert	20
RCA348 Carbide Seat Insert	20
Suggested 37.5 Degree Seat Inserts	21
RCA401 Carbide Seat Insert	21
Suggested Straight Angle Seat Inserts	21
RCA511 Carbide Seat Insert	21
RCA512 Carbide Seat Insert	21
RCA513 Carbide Seat Insert	21
RCA501 Carbide Seat Insert	22
RCA521 Carbide Seat Insert	22
RCA502 Carbide Seat Insert	22
RCA503 Carbide Seat Insert	22
RCB506 Carbide Seat Insert	22
Suggested 45 Degree Seat Inserts for Multi-Valves Cylinder Heads	23
RCA632 Carbide Seat Insert	23
RCA637 Carbide Seat Insert	23
High Performance Inserts	24
RCB605 Carbide Seat Insert	24
RCB607 Carbide Seat Insert	24
RCB608 Carbide Seat Insert	24
RCA614 Carbide Seat Insert	24
RCB620 Carbide Seat Insert	25
RCB621 Carbide Seat Insert	25
RCA623 Carbide Seat Insert	25
Harley Davidson Inserts	26
RCA626 Carbide Seat Insert	26
RCA633 Carbide Seat Insert	26
RCA640 Carbide Seat Insert	26
Counterboring and Straight Angles Inserts	26
RCA511 Carbide Seat Insert	26
RCA512 Carbide Seat Insert	26
RCA513 Carbide Seat Insert	26

RT211 Insert, triangular.....	27
RT212 Insert, triangular	27
Rottler Special Profile Cutter Inserts Policy	27
Available Carbide Pilots by Diameter and Length.....	28
Miscellaneous Tooling	29
CDR312 Combo Core drill / Reamer	29
CDR343 Combo Core drill / Reamer	29
CDR375 Combo Core drill / Reamer	29
VSD100-KIT Valve Seat Driver Kit	30
VGD-KIT Valve Guide Driver Kit	31
VGTC-KIT3 Valve Guide Top Cutter Kit	31
Fixed Double Insert Milling Heads	32
FMH10000R1 1.0000" Fixed Double Replaceable Insert Milling Head.....	32
FMH10625R1 1.0625" Fixed Double Replaceable Insert Milling Head.....	32
FMH11250R1 1.1250" Fixed Double Replaceable Insert Milling Head.....	32
FMH11875R1 1.1875" Fixed Double Replaceable Insert Milling Head.....	32
FMH13125R1 1.3125" Fixed Double Replaceable Insert Milling Head.....	32
FMH13750R1 1.3750" Fixed Double Replaceable Insert Milling Head.....	32
FMH14375R1 1.4375" Fixed Double Replaceable Insert Milling Head.....	33
FMH15000R1 1.5000" Fixed Double Replaceable Insert Milling Head.....	33
FMH15625R1 1.5625" Fixed Double Replaceable Insert Milling Head.....	33
FMH16250R1 1.6250" Fixed Double Replaceable Insert Milling Head.....	33
FMH16875R1 1.6875" Fixed Double Replaceable Insert Milling Head.....	33
FMH17500R1 1.7500" Fixed Double Replaceable Insert Milling Head.....	33
FMH18125R1 1.8125" Fixed Double Replaceable Insert Milling Head.....	34
FMH18750R1 1.8750" Fixed Double Replaceable Insert Milling Head.....	34
FMH20000R1 2.0000" Fixed Double Replaceable Insert Milling Head.....	34
Consumable Parts for Seat and Guide Models.....	35
SLEEVE1 Spindle Adapter Replacement Sleeve	35
BSW002 Diamond Wheel	35
VT-FP1562 Replacement Foam Pad.....	35
VT-FP1875 Replacement Foam Pad.....	35
VT-FP2125 Replacement Foam Pad.....	35
VT-FP3125 Replacement Foam Pad.....	35
VT-FP25X22 Replacement Foam Pad	35
VT-FP31X20 Replacement Foam Pad	35
VT-FP33X27 Replacement Foam Pad	35
PRW600PIN Replaceable Pin.....	36
PRW375PIN Replaceable Pin.....	36



PRW20PIN Replaceable Pin.....	36
511-29-12E Torx Screw.....	36
T7D T7 Torx Driver.....	36
T8S T8 Torx Tip Holding Screws.....	36
T15S T15 Torx Tip Holding Screws.....	36
S1032-250 BH375R1 and BH600R1 Tip Holder Locking Screw.....	36
S250-28-250 BH375WR1 Tip Holder Locking Screw.....	36
S1032-437 TH1999 Adjusting Screw.....	36
S1032-375 TH2000 Adjusting Screw.....	36
S1032-500 TH2001 Adjusting Screw.....	36
S1032-625 TH2002 Adjusting Screw.....	36
S500-1600 TH2003 Adjusting Screw.....	36
S600-2015 TH2004 Adjusting Screw.....	36
ICC003 Insert, Indexable Carbide.....	36
ICC002 Insert, Indexable Carbide.....	36
Optional Fixtures.....	37
PER-FIX Pneumatic Quick Clamping Production Fixture.....	37
STD-FIX Universal Heavy Duty Bolt Down 360 degree Roll Over Cylinder Head Fixture.....	38

Rottler UNIPILOT Spindle Adapters and Tool Holders

**UPT5200 Rottler (Patent Pending)
Unipilot Tool Holder**
Range 0.787 - 2.360" (20.00 - 60.00mm)



**UPT5400 Rottler (Patent Pending)
Unipilot Tool holder**
Range 2.280 - 3.150" (58 - 80mm)



Rottler R1 Taper Tool Holders

**UPTRS105 Rottler R1 Spindle Taper
Milling Head Driver**
For fixed and adjustable valve seat installation
counterbore cutters for .625" ID cutter bodies.



**RS105 Rottler R1 Spindle Taper Milling Head
Driver**
For fixed and adjustable replaceable milling head cutters for
(15.88mm) .625" ID milling head body.

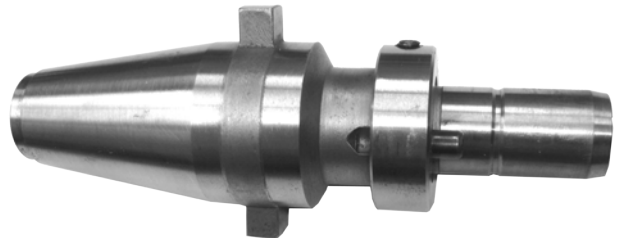

RS560 Rottler R1 Spindle Taper Milling Head Driver

For fixed and adjustable replaceable milling head cutters for (14.27mm) .562" ID Diameter Milling Heads



SAD500R1 Spindle Adapter

For Rottler R1 Spindle Taper for 1/2" (12.70mm) Shank Diameter Tools, reamers, drills, etc includes two locking set screws



SAD375R1 Spindle Adapter

For Rottler R1 Spindle Taper for 3/8" (9.525mm) Shank Diameter Tools, reamers, drills, etc includes two locking set screws



PC375R1 Universal Three Jaw Chuck

Including Spindle Adapter for Rottler R1 Spindle Taper

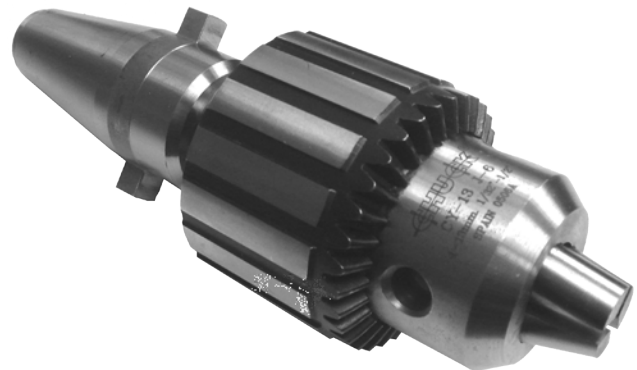

COLLET-KITR1

Collet chuck set of (8) collets Includes: 3/16, 7/32, 1/4, 5/16, 11/32, 3/8, 7/16, 1/2" (4.775, 5.556, 6.35, 7.938, 8.731, 9.525, 11.113, 12.7mm) Spring Collets, Collet Chuck Spindle Adapter with Collet Nut for Rottler R1 Spindle Taper and Spanner Wrench for Collet Chuck



R1MT3 Adapter for Morse #3 to Rottler R1 taper



Tip Holders for Valve Seat Angle Cutting

TH1999 Tip Holder

Range using the BH600-R1: .570 - 1.250" (14.48 - 33.52mm) (Using RCA630 Cutting Insert for minimum range) Range with BH375R1: .800 - 1.320" (20.32 - 33.52mm Using RCA630 Cutting Insert for minimum range)



TH2000 Tip Holder

Range using the BH600-R1: .597 - 1.180" (15.16 - 30mm) (Using RCA630 Cutting Insert for minimum range) Range with BH375R1: .800 - 1.395" (20.32 - 35.43mm Using RCA630 Cutting Insert for minimum range)



TH2001 Tip Holder

Range using the BH600-R1: .850 - 1.625" (21.6 - 41.3mm) (Using RCA630 Cutting Insert for minimum range) Range with BH375R1: 1.00 - 1.800" (25.4 - 35.4mm Using RCA630 Cutting Insert for minimum range)



TH2002 Tip Holder

Range using the BH600-R1: 1.200 - 2.360" (30.48 - 60.0mm) (Using RCA630 Cutting Insert for minimum range) Range with BH375R1: 1.270 - 2.360" (32.26 - 59.94mm Using RCA630 Cutting Insert for minimum range)

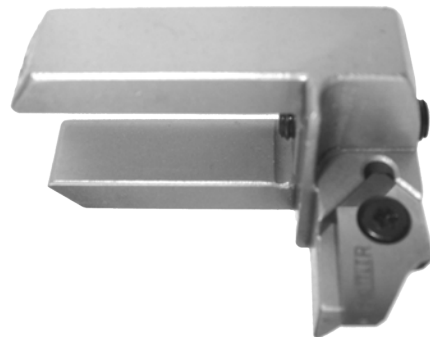

TH2003 Tip Holder

Range: 1.270 - 2.360" (32.26 - 60mm) (Using RCA630 Cutting Insert for minimum range) for BH375WR1 Tool holder Only.

**TH2004 Tip Holder**

Range: 1.850 - 3.150" (47 - 80mm) (Using RCA630 Cutting Insert for minimum range) for BH375WR1 Tool holder Only.

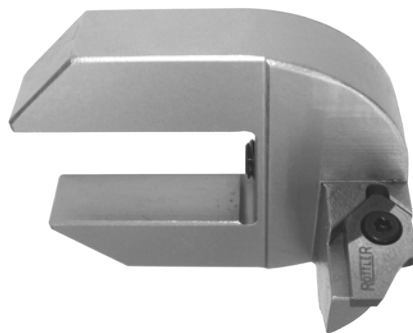
**TH2005 Tip Holder**

Range: 2.625 - 4.724" (66.7 - 120mm) (Using RCA630 Cutting Insert for minimum range) for BH375WR1 Tool holder Only.



Suggested Basic Tooling

<p>PRW375 Pilot Removal Wrench For .375" (9.252mm) pilot shank</p> 	<p>PRW600 Pilot Removable Wrench For 6.00mm shank pilot</p> 
<p>T8D T8 Torx Tip Holding Screw Driver</p> 	<p>T7D T7 Torx Driver For RT211 & RT212 (1/4" I.C.) insert</p> 
<p>ALLEN-KEYS-IN Inch Ball end hex Allen Key Set Drivers From: 1/16 - 3/8"</p> 	<p>ALLEN-KEYS-MM Metric Ball end hex Allen Key Set</p> 

Micrometers Setting Fixtures and Measurement Tools

DSP Tool setting Device with Interchangeable Point



BM Boring Micrometer, Digital Reading Inch and Metric

(.800 - 2.80") with setting standard for .375" (9.52mm) and 6.00mm (152.40mm) shank diameter



6-1SETTINGFIX

Six in one measuring Fixture (Pilot OD, Valve Stem OD, Set diameter on profile inserts, Setting 90 degree counterboring inserts, Set adjustable milling head cutters, Check alignment on valve stem and check roundness on valve stems.



VSG102-375 Precision Valve Seat Concentricity Gage Base Only

For .375" Pilot Shank (Must Order dial indicator .0001" or
.002mm Metric indicator)

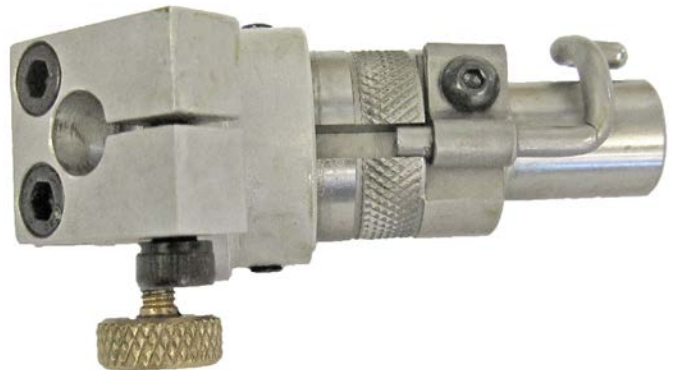

VSG102-6MM Precision Valve Seat Concentricity Gage Base Only

For 6.00mm Pilot Shank, Base Only (Must Order dial indicator .0001" or .002mm Metric indicator)

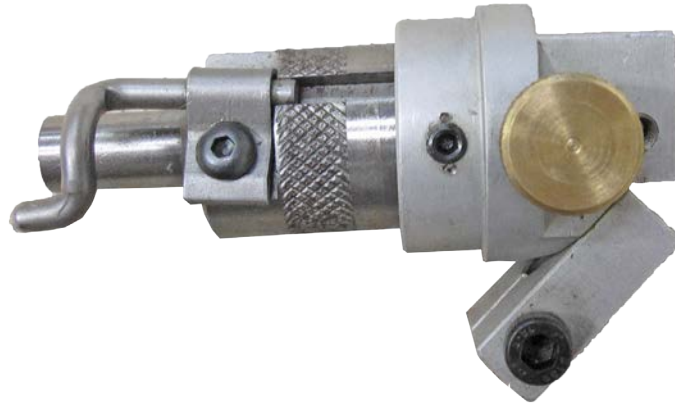

502-11-39L Mechanical Run Out Indicator

For precision bore adjustment (.002mm resolution)
METRIC



502-11-39D Mechanical run out indicator

For Precision bore adjustment (.0001" resolution) INCH



Special Fixtures, Clamps and Parallels

DIESELFIX Diesel Fixture

For large in line cylinder heads, includes one pair Parallels 12 X 6" (304.80 X 152.40mm) (1) Jack screw to support sagging in the middle when working on large heads. Requires one pair of two Low Profile Clamp Tower 7242T

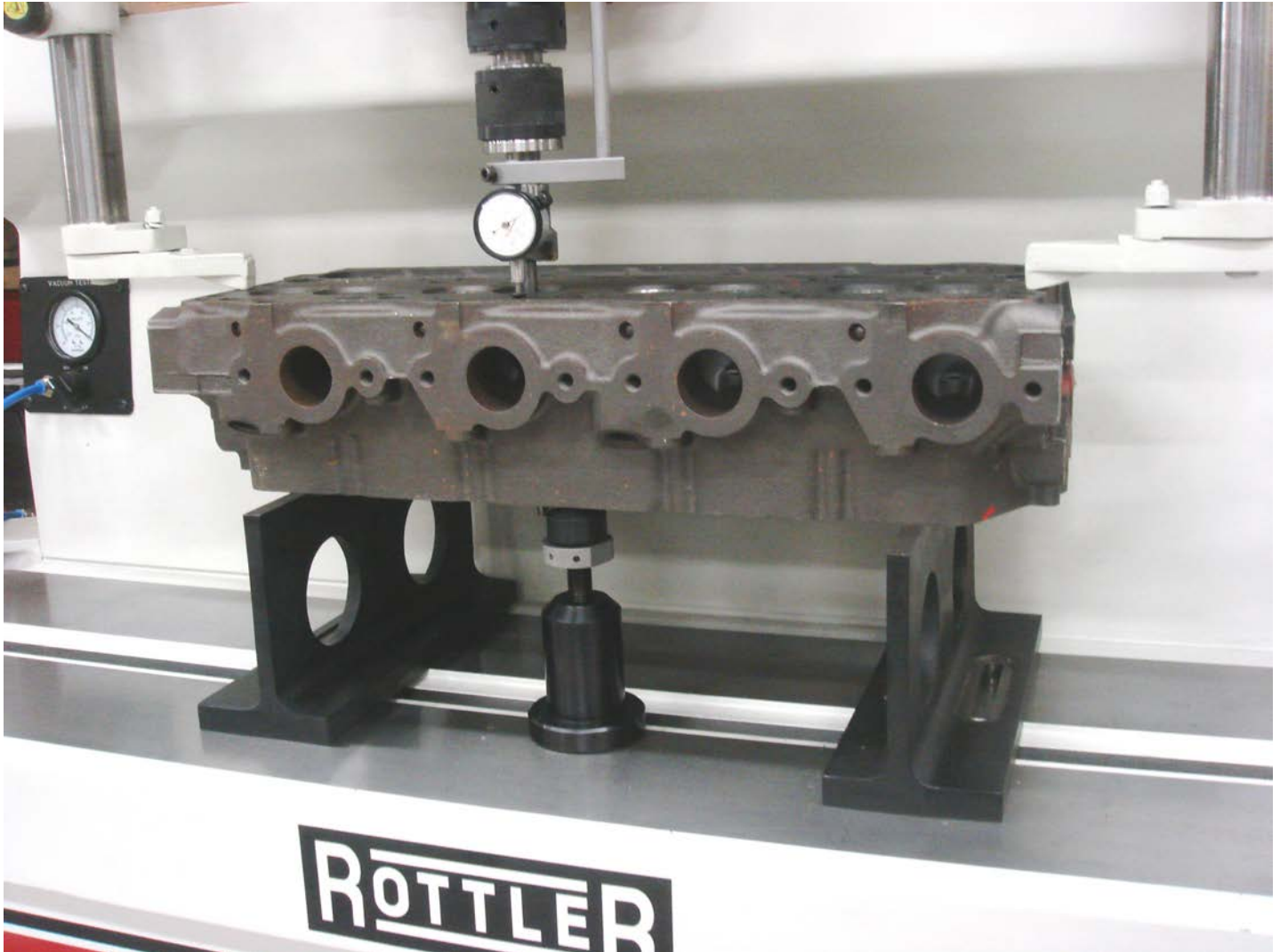

7242T Low Profile Clamp Tower Assembly



CANTEDFIX Canted Fixture

For leveling canted cylinder heads on Any fixed pilot Seat and Guide Machine

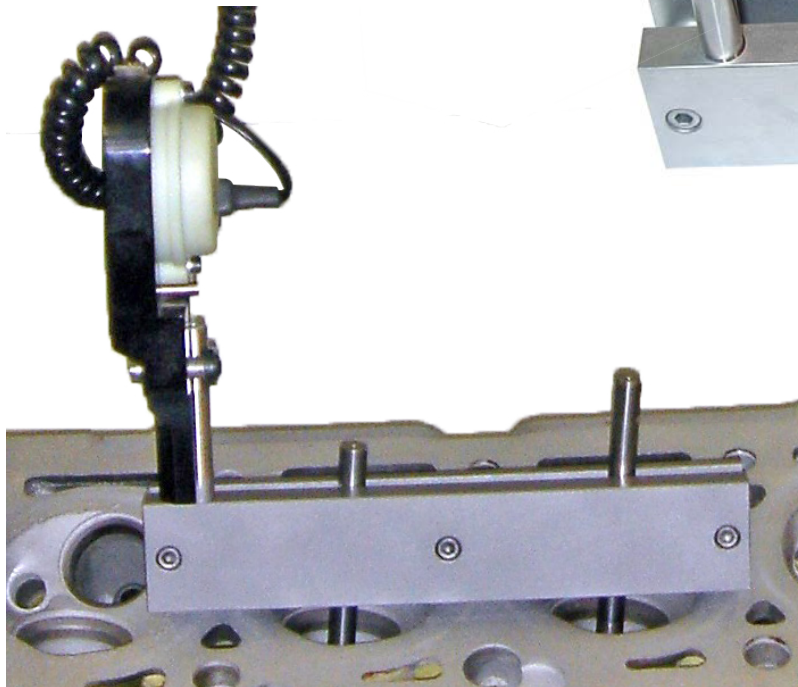

7618 Large Cylinder Head Clamping Fixture
(CAT 3406E or large diesel cylinder head)

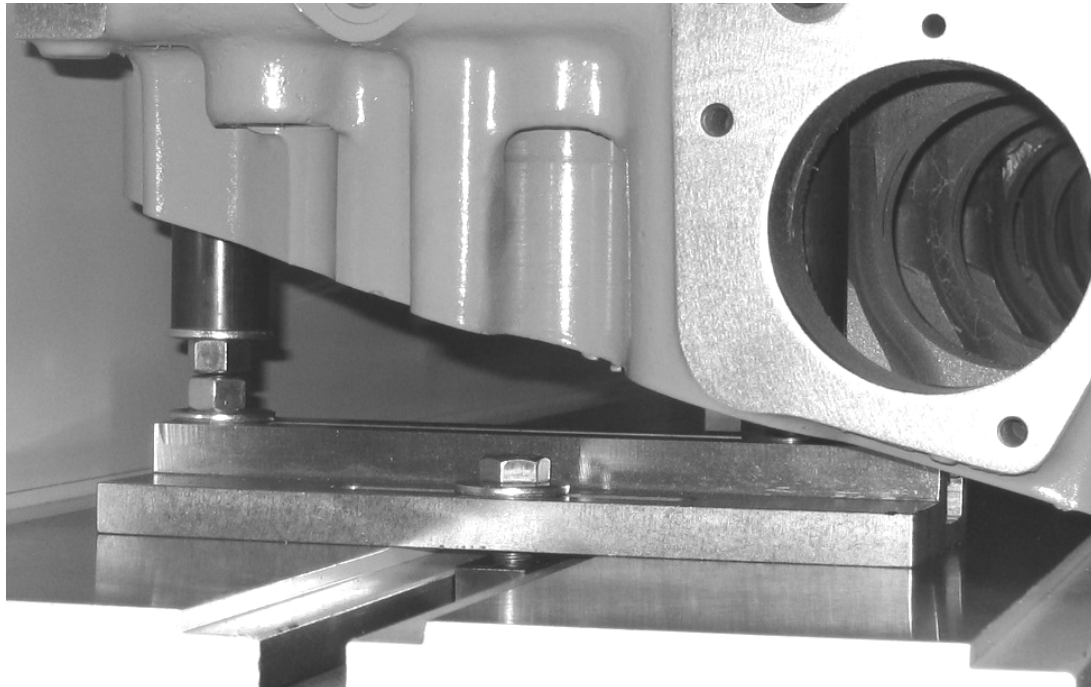

Triangular Insert Tip Holders

For Valve Seat Installation Counterboring for RT211 (1/4" I.C.) Rottler Triangular Insert Only

TH2000-00 00 Degree Triangular Tip Holder

For Valve Seat Installation Counterboring. Uses RT211, 1/4" IC Triangular Insert. Requires BH375R1 Self Aligning Tool holder. Range with BH600R1: 1.055 - 1.400" (26.797 - 26.8mm). Range with BH375R1: 1.27 - 1.58" (32.258 - 40.132mm)



TH2001-00 00 Degree Triangular Tip Holder

For Valve Seat Installation Counterboring. Uses RT211 (1/4" I.C.) Triangular Insert. Requires BH375R1 Self Aligning Tool holder. Range: 1.100 - 1.570" (28 - 42mm)

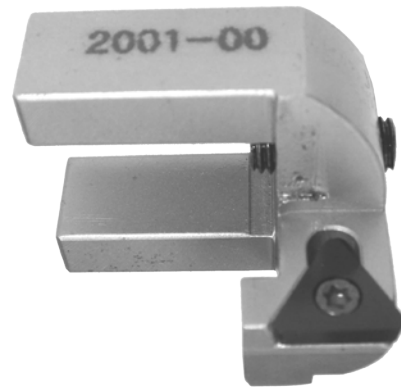

TH2002-00 00 Degree Triangular Tip Holder

For Valve Seat Installation Counterboring. Uses RT211 (1/4" I.C.) Triangular Insert. Requires BH375R1 Self Aligning Tool holder. Range: 1.570 - 2.360" (40 - 60mm)

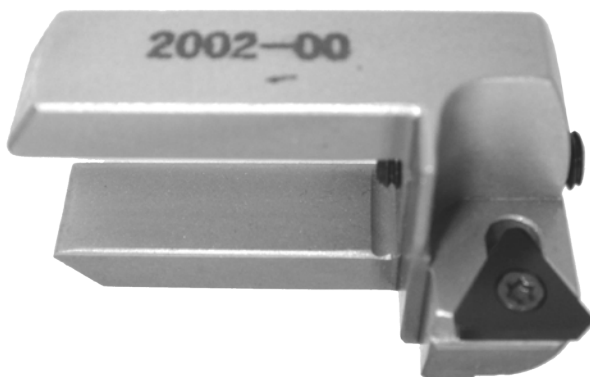

TH2003-00 00 Degree Triangular Tip Holder

For Valve Seat Installation Counterboring. Uses RT211 (1/4" I.C.) Triangular Insert. Requires BH375WR1 Self Aligning Tool holder. Range: 1.570 - 2.360" (40 - 60mm)



TH2004-00 00 Degree Triangular Tip Holder

For Valve Seat Installation Counterboring. Uses RT211 (1/4" I.C.) Triangular Insert. Requires BH375WR1 Self Aligning Tool holder. Range: 2.280 - 3.150" (58 - 80mm)

**TH2005-00 00 Degree Triangular Tip Holder**

For Valve Seat Installation Counterboring. Uses RT211 (1/4" I.C.) Triangular Insert. Requires BH375WR1 Self Aligning Tool holder. Range: 3.071 - 4.724" (78 - 120mm)

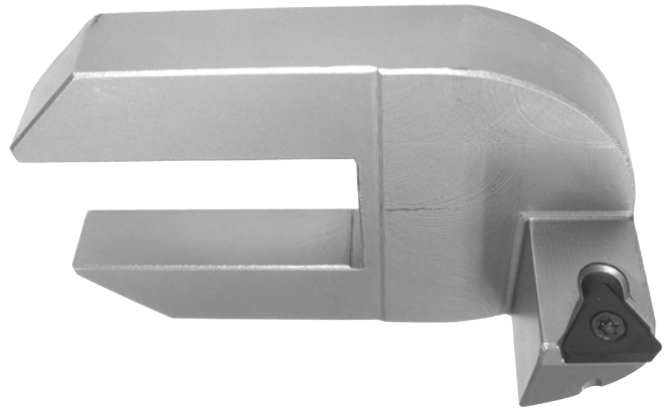
**Triangular Insert Holders**

For Single Angle Valve Seat Cutting for RT211 (1/4" I.C.) Rottler Triangular Insert Only

TH2002-30 30 Degree Triangular Tip Holder

For 30 Degree Valve Seat Angle Cutting. Uses RT211 (1/4" I.C.) Triangular Insert. Requires BH375R1 Self Aligning Tool holder. Range: 1.570 - 2.360" (40 - 60mm)

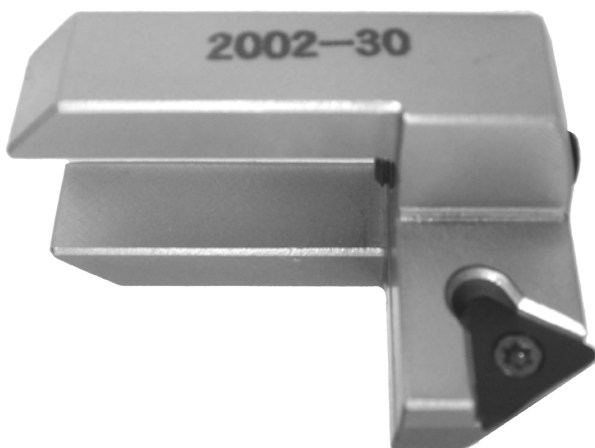
**TH2002-45 45 Degree Triangular Tip Holder**

For 45 Degree Valve Seat Angle Cutting. Uses RT211 (1/4" I.C.) Triangular Insert. Requires BH375R1 Self Aligning Tool holder. Range: 1.570 - 2.360" (40 - 60mm)

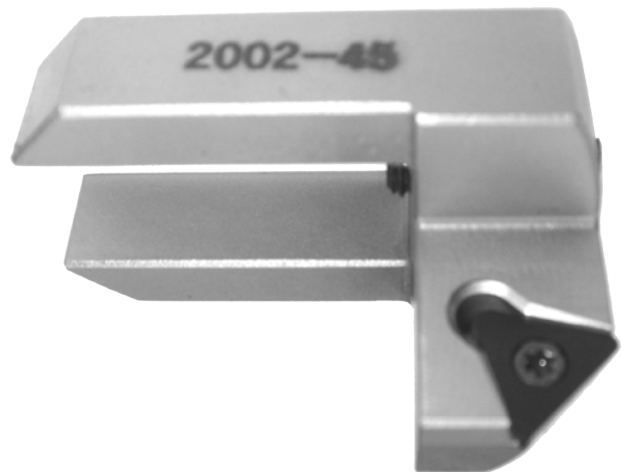

TH2003-20 20 Degree Triangular Tip Holder

For Valve Seat Angle Cutting. Uses RT211 (1/4" I.C.)
Triangular Insert. Requires BH375WR1 Self Aligning Tool
holder. Range: 1.570 - 2.360" (40 - 60mm)

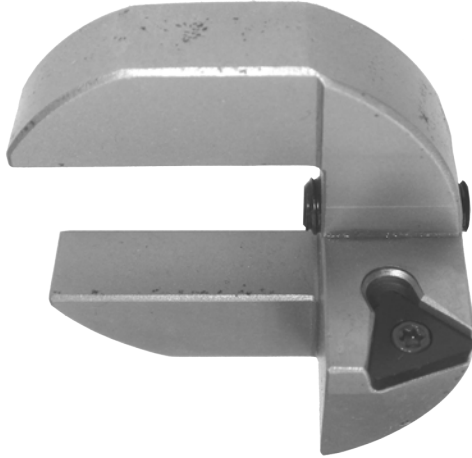
**TH2003-30 30 Degree Triangular Tip Holder**

For Valve Seat Angle Cutting. Uses RT211 (1/4" I.C.)
Triangular Insert. Requires BH375WR1 Self Aligning Tool
holder. Range: 1.570 - 2.360" (40 - 60mm)

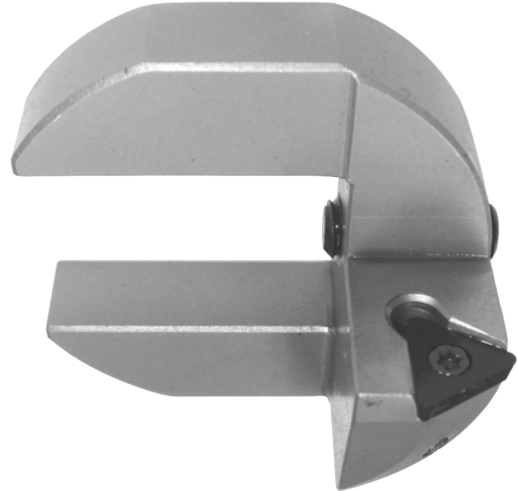
**TH2003-45 45 Degree Triangular Tip Holder**

For Valve Seat Angle Cutting. Uses RT211 (1/4" I.C.)
Triangular Insert. Requires BH375WR1 Self Aligning Tool
holder. Range: 1.570 - 2.360" (40 - 60mm)

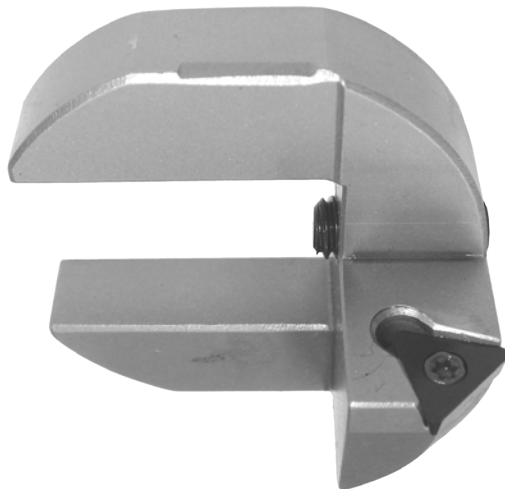
**TH2004-20 20 Degree Triangular Tip Holder**

For Valve Seat Angle Cutting. Uses RT211 (1/4" I.C.)
Triangular Insert. Requires BH375WR1 Self Aligning Tool
holder. Range: 2.280 - 3.150" (58 - 80mm)

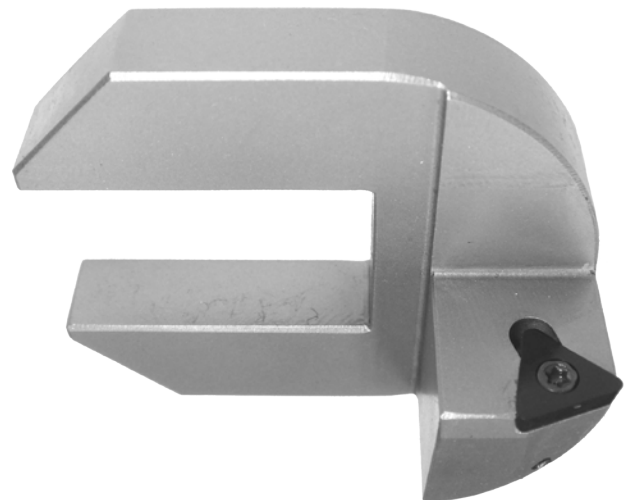

TH2004-30 30 Degree Triangular Tip Holder

For Valve Seat Angle Cutting. Uses RT211 (1/4" I.C.)
Triangular Insert. Requires BH375WR1 Self Aligning Tool
holder. Range: 2.280 - 3.150" (58 - 80mm)

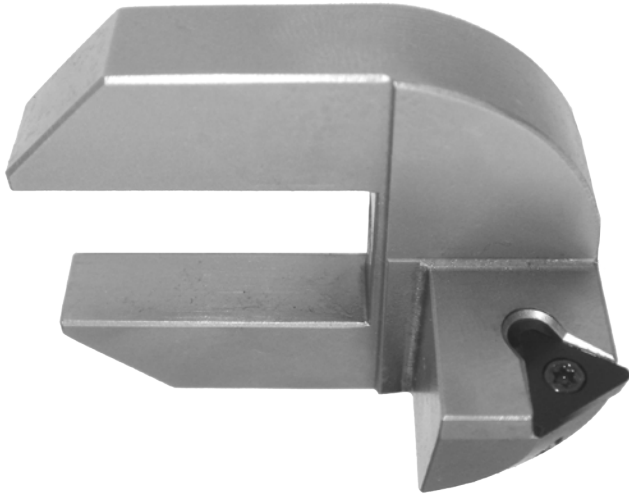
**TH2004-45 45 Degree Triangular Tip Holder**

For Valve Seat Angle Cutting. Uses RT211 (1/4" I.C.)
Triangular Insert. Requires BH375WR1 Self Aligning Tool
holder. Range: 2.280 - 3.150" (58 - 80mm)

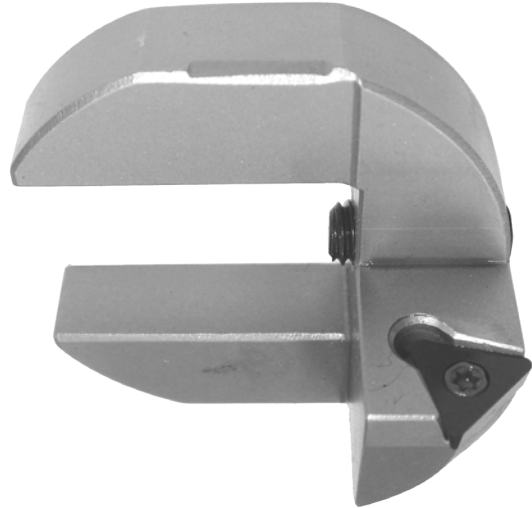
**TH2005-20 20 Degree Triangular Tip Holder**

For Valve Seat Angle Cutting. Uses RT211 (1/4" I.C.)
Triangular Insert. Requires BH375WR1 Self Aligning Tool
holder. Range: 3.071 - 4.724" (78 - 120mm)

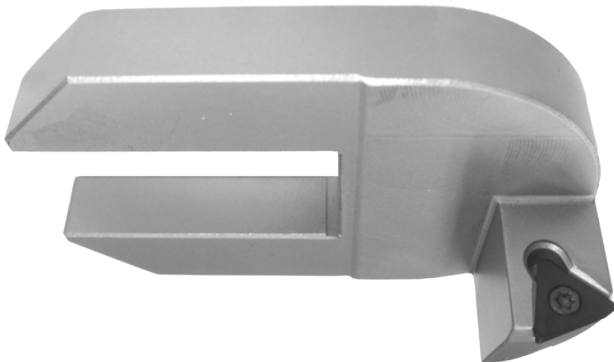
**TH2005-30 30 Degree Triangular Tip Holder**

For Valve Seat Angle Cutting. Uses RT211 (1/4" I.C.)
Triangular Insert. Requires BH375WR1 Self Aligning Tool
holder. Range: 3.071 - 4.724" (78 - 120mm)



TH2005-45 45 Degree Triangular Tip Holder

For Valve Seat Angle Cutting. Uses RT211 (1/4" I.C.)
Triangular Insert. Requires BH375WR1 Self Aligning Tool
holder. Range: 3.071 - 4.724" (78 - 120mm)

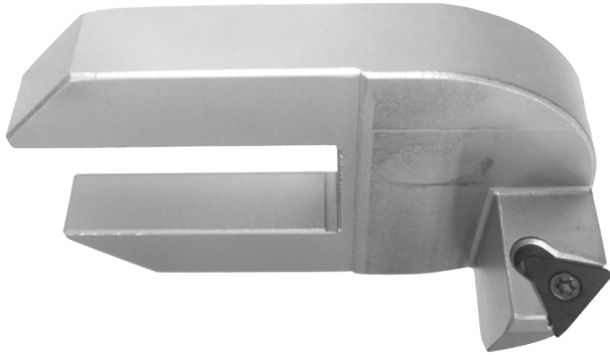
Triangular Inserts and Torx Driver for the Previous Insert Holders
RT211 Triangular Insert

1/4" (6.35mm) I.C., 1/64" radius FOR COUNTERBORING
and SINGLE ANGLE INSERT HOLDERS

RT212 Triangular Insert

1/4" (6.35mm) I.C., 1/32" radius FOR COUNTERBORING
and SINGLE ANGLE INSERT HOLDERS

T7D T7 Torx Driver

For RT-211 & RT-212 (1/4" I.C.) insert



CUTTING INSERTS

NOTE: For Recommended Inserts, see Inserts and Profile Catalog

Select the correct Insert profile to match the original factory valve seat shape. The relief angle and the seating surface width and angle must match.

All specifications can be obtained from the original manufacturer's manual.

Select the proper Insert base on the application RCA insert profiles are design for regular three angle seat profiles, make sure the that top angle will not go over the seat insert,

RCB inserts Profiles are design for a multiple angles and radius and is recommended for High performance profiles.

Cutting Insert Sharpener for Multi Angle Inserts

BWS02 Diamond Wheel Cutting Bit Sharpener - Single Wheel



Rottler Profile Cutter Inserts

RCAXXX Carbide Cutting Bits RC multi-angle A Blank (Standard Profile)

RCBXXX Carbide Cutting Bits RC multi-angle B Blank (standard Profile)

RCCXXX Carbide Cutting Bits RCC Single Angle C Blank (Standard Profile) for T15 Screw (for large tooling only)

NOTE: See Carbide inserts spreadsheet for list of additional inserts RCAXXX reference. (Large tooling will take RCCXXX insert type only)

Automotive Import, Domestic and Diesel Inserts

Suggested 45 Degree Seat Inserts

NOTE: Orders of 20+ of the same RCA insert receive 10% discount. Orders of 50+ of the same RCA insert receive 20% discount. Does not apply to mix-and-match orders.

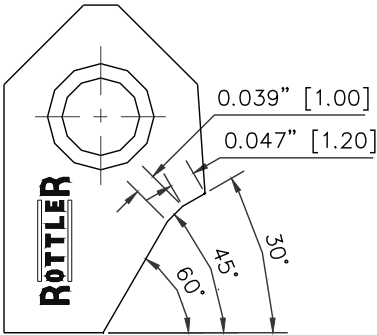
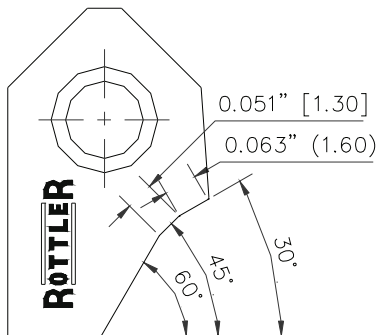
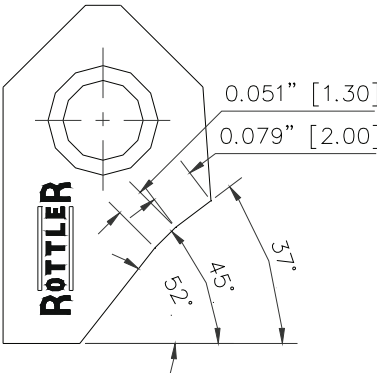
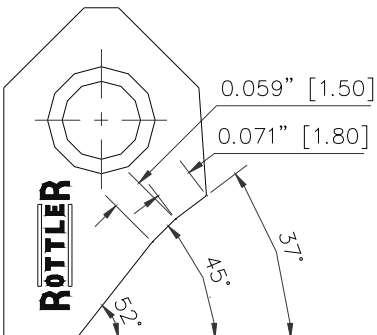
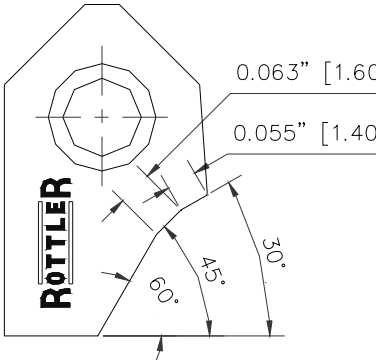
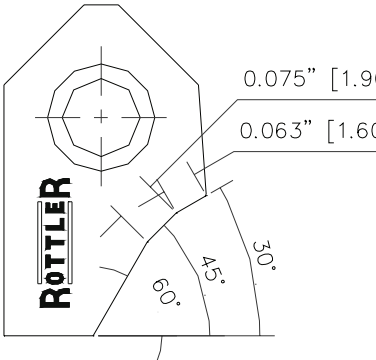
<p>RCA001 Carbide Seat Insert 30-45-60 / 1.2 -1.0mm</p> <p>RCA-001 (14 RC BIT KIT)</p> 	<p>RCA004 Carbide Seat Insert 30-45-60 / 1.6 -1.3mm</p> <p>RCA-004 (14 RC BIT KIT)</p> 	<p>RCA005 Carbide Seat Insert 37-45-52 / 2.0 -1.3mm</p> <p>RCA-005 (14 RC BIT KIT)</p> 
<p>RCA007 Carbide Seat Insert 37-45-52 / 1.8 -1.5mm</p> <p>RCA-007 (14 RC BIT KIT)</p> 	<p>RCA014 Carbide Seat Insert 30-45-60 / 1.4 -1.6mm</p> <p>RCA-014 (14 RC BIT KIT)</p> 	<p>RCA026 Carbide Seat Insert 30-45-60 / 1.6 -1.9mm</p> <p>RCA-026 (14 RC BIT KIT)</p> 

Suggested 30 Degree Seat Inserts

NOTE: Orders of 20+ of the same RCA insert receive 10% discount. Orders of 50+ of the same RCA insert receive 20% discount. Does not apply to mix-and-match orders.

<p>RCA301 Carbide Seat Insert 5-30-45 / 2.0 -1.3mm</p> <p>RCA-301 (14 RC BIT KIT)</p>	<p>RCA303 Carbide Seat Insert 15-30-45 / 1.4 -1.5mm</p> <p>RCA 303</p>	<p>RCA307 Carbide Seat Insert 15-30-45 / 1.8 -1.6mm</p> <p>RCA-307 (14 RC BIT KIT)</p>
<p>RCA348 Carbide Seat Insert 10-30-60 top width 2.2mm, seat width 1.8mm OFFSET Insert (For Detroit 53 Series Cylinder Head)</p> <p>RCA 348</p>		

Suggested 37.5 Degree Seat Inserts

NOTE: Orders of 20+ of the same RCA insert receive 10% discount. Orders of 50+ of the same RCA insert receive 20% discount. Does not apply to mix-and-match orders.

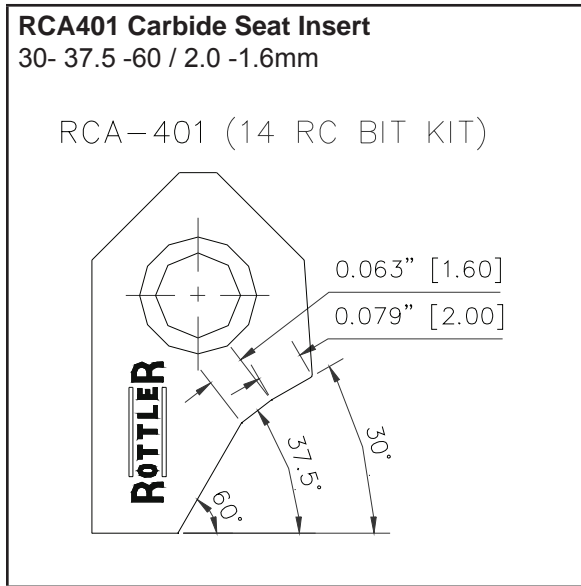

Suggested Straight Angle Seat Inserts

NOTE: Orders of 20+ of the same RCA insert receive 10% discount. Orders of 50+ of the same RCA insert receive 20% discount. Does not apply to mix-and-match orders.

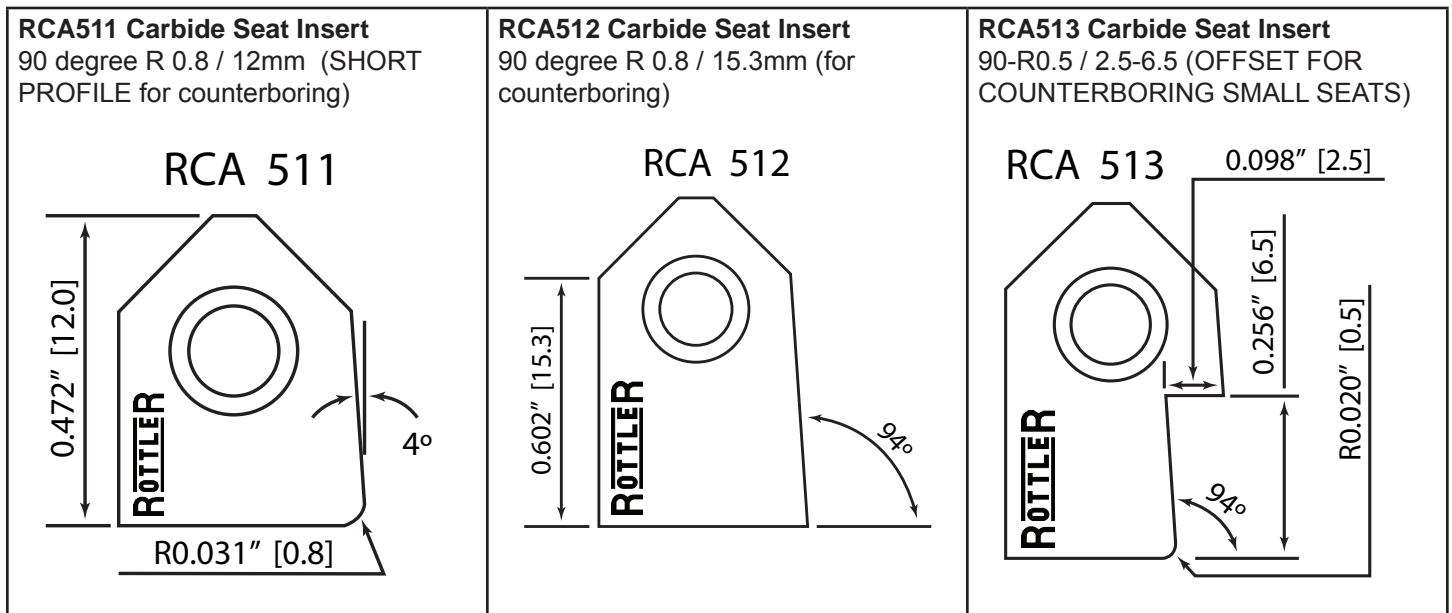

<p>RCA501 Carbide Seat Insert 20 degrees / 8.8mm</p> <p>RCA 501</p>	<p>RCA521 Carbide Seat Insert 25 degrees / 8.5mm</p> <p>RCA 521</p>	<p>RCA502 Carbide Seat Insert 30 degrees / 9.0mm</p> <p>RCA-502 (14 RC BIT KIT)</p>
<p>RCA503 Carbide Seat Insert 45 degrees / 8.9mm</p> <p>RCA 503</p>	<p>RCB506 Carbide Seat Insert 70 degrees / 16.8mm</p> <p>RCB 506</p>	

Suggested 45 Degree Seat Inserts for Multi-Valves Cylinder Heads

NOTE: Orders of 20+ of the same RCA insert receive 10% discount. Orders of 50+ of the same RCA insert receive 20% discount. Does not apply to mix-and-match orders.

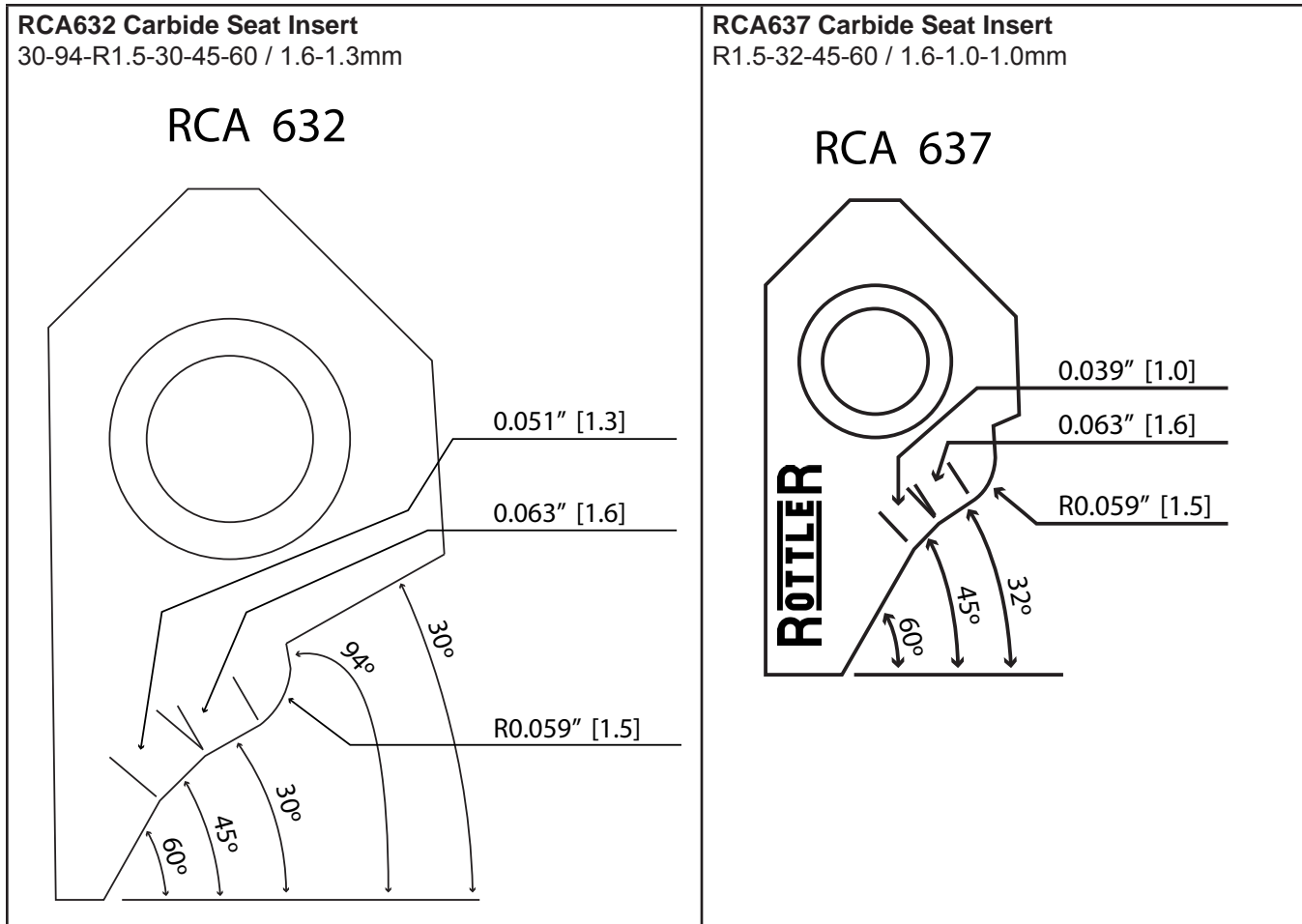

High Performance Inserts

NOTE: Orders of 20+ of the same RCA insert receive 10% discount. Orders of 50+ of the same RCA insert receive 20% discount. Does not apply to mix-and-match orders.

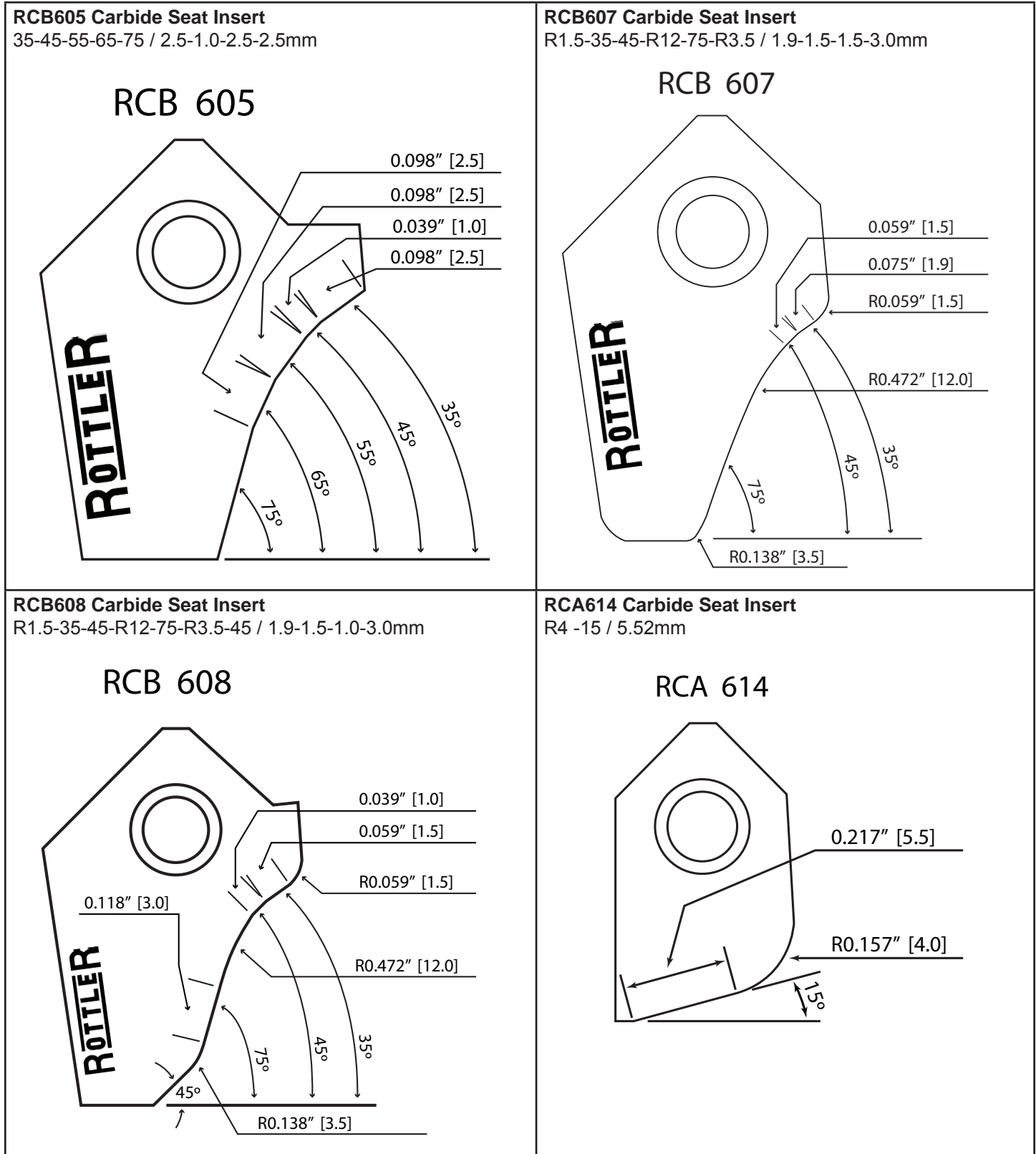

RCB620 Carbide Seat Insert
R7 -15

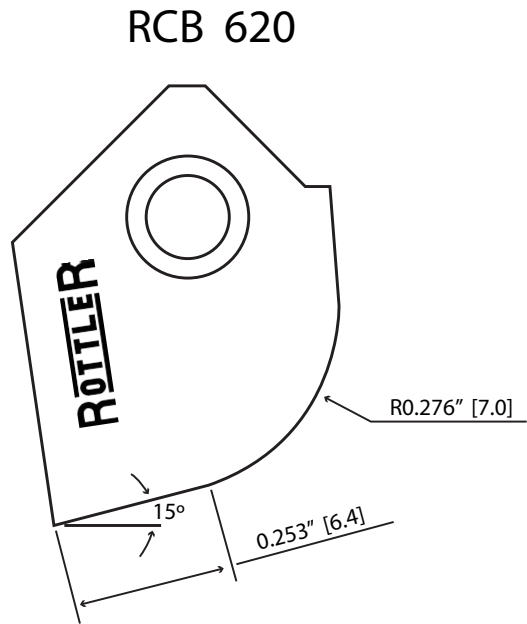

RCB621 Carbide Seat Insert
75 - R7 / 12.0mm

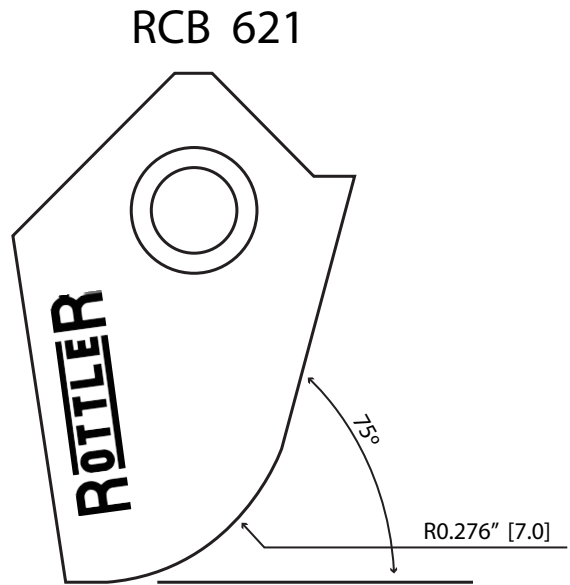

RCA623 Carbide Seat Insert
R0.8-30-45-60-R13-R1.5 / 1.0-1.0mm

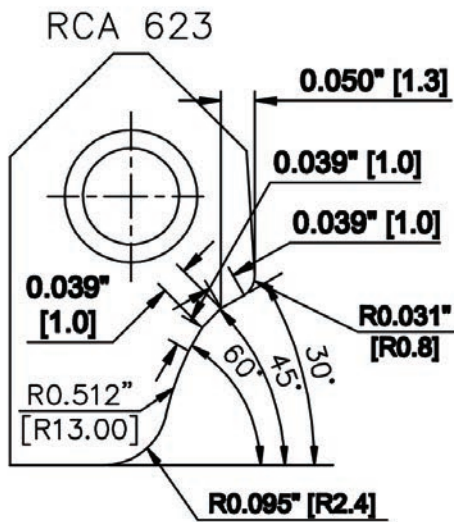

Harley Davidson Inserts

NOTE: Orders of 20+ of the same RCA insert receive 10% discount. Orders of 50+ of the same RCA insert receive 20% discount. Does not apply to mix-and-match orders.

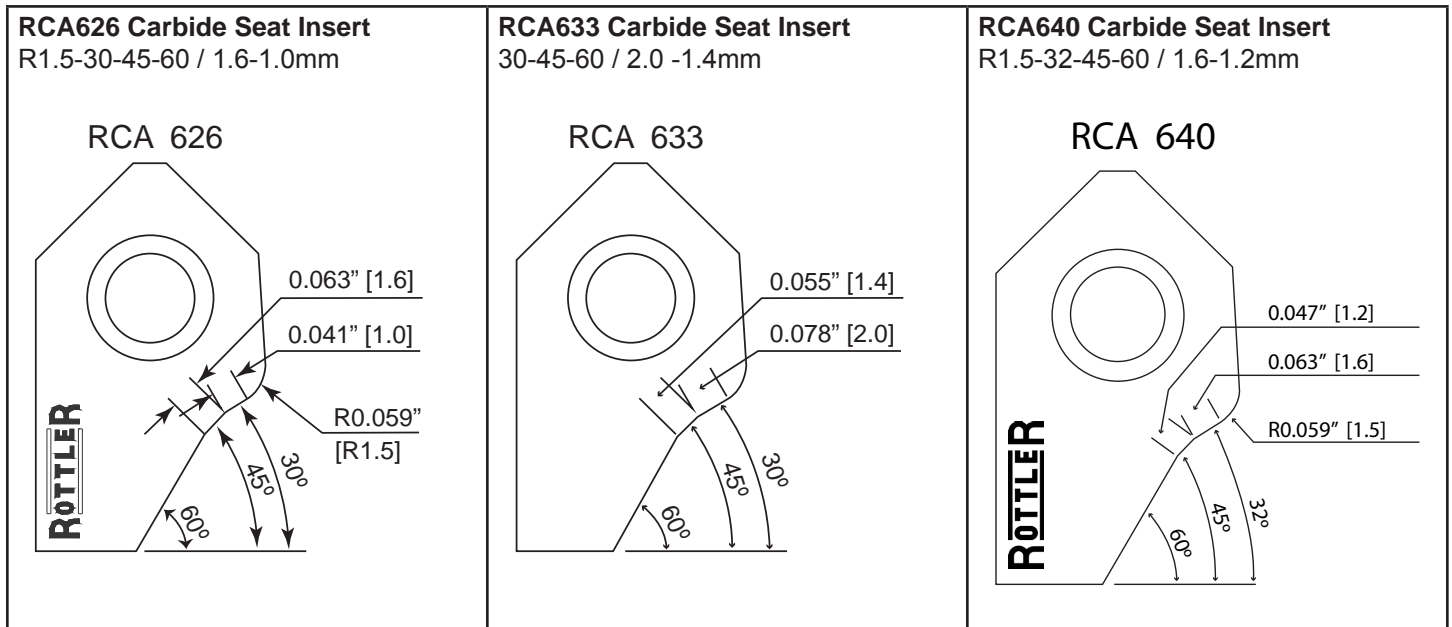

Counterboring and Straight Angles Inserts

NOTE: Orders of 20+ of the same RCA insert receive 10% discount. Orders of 50+ of the same RCA insert receive 20% discount. Does not apply to mix-and-match orders.

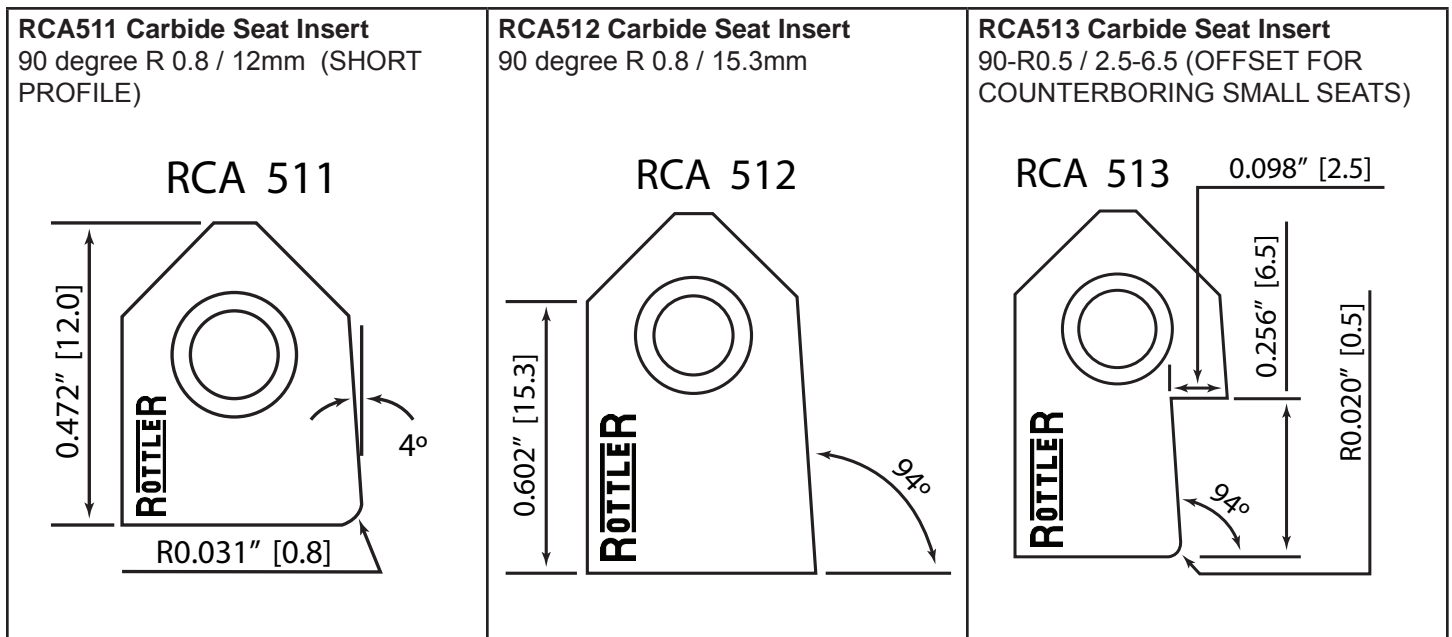

RT211 Insert, triangular

1/4" (6.35mm) 1/64" radius (1/4" triangle Insert holders only) FOR COUNTERBORING FOR INSERT HOLDERS THAT USE TRIANGLE INSERT STYLE.

**RT212 Insert, triangular**

1/4" (6.35mm) 1/32" radius (1/4" triangle Insert holders only) FOR COUNTERBORING FOR INSERT HOLDERS THAT USE TRIANGLE INSERT STYLE.



Rottler Special Profile Cutter Inserts Policy

Special Profile Cutter Inserts can be manufactured to your exact specifications and can include a combination of angles and radius blends. Special Profile Carbide Cutter Bits are generally considered to be "Customer Proprietary". These are uniquely numbered, exclusively for the ordering customer.

Contact Rottler Manufacturing for further information.

Available Carbide Pilots by Diameter and Length

NOTE: For Recommended Fixed Carbide, See SG Pilot Catalog.

UCPM-MINI	UNIPILOT Carbide Pilots with 6.00mm Shank Diameter / 5.700" long range from 3.50 - 7.00mm to be used on BH600-R1 Tool Holder and TH1999 Tip Holder)
UCP-5TO10STD	UNIPILOT Carbide Pilots UCP .375" (9.52mm) Shank Diameter / Total Length 7.500" Range from .196 - .394" (5.00 - 10.00mm)
UCP-10TO12STD	UNIPILOT Carbide Pilots UCP .375" (9.52mm) Shank Diameter / Total Length 7.500" Range from .390 - .470" (10.01 - 12.00 mm)
UCP-12TO14STD	UNIPILOT Carbide Pilots UCP .375" (9.52mm) Shank Diameter / Total Length 7.500" Range from .470 - .550" (12.01 - 14.00 mm)
UCP-14TO16STD	UNIPILOT Carbide Pilots UCP .375" (9.52mm) Shank Diameter / Total Length 7.500" Range from .551 - .630" (14.01 - 16.00mm)
UCP-UNDER10-9EL	UNIPILOT Carbide Pilot .375" (9.52mm) Shank Diameter Below .390" 10.00mm (9.00" extended length)
UCP-10TO14-9EL	UNIPILOT Carbide Pilot .375" (9.52mm) Shank Diameter (9.00" extended length) from 10.02 - 14.50mm
UCP-14TO16-9EL	UNIPILOT Carbide Pilot .375" (9.52mm) Shank Diameter (9.00" extended length) from 14.02 - 16.00mm
UCP-16TO19-9EL	UNIPILOT Carbide Pilot .375" (9.52mm) Shank Diameter (9.00" extended length) from 16.02 - 19.50mm
UCP-10TO14-12EL	UNIPILOT Carbide Pilot .375" (9.52mm) Shank Diameter (12.00" extended length) from 10.02 - 14.50mm
UCP-20MM	Any UNIPILOT Carbide Pilot 20.00mm Shank Diameter Up to 22.00mm pilot Diameter

Miscellaneous Tooling

CDR312 Combo Core drill / Reamer

.312" Pilot to bore for standard 1/2" OD valve guide insert with .375" diameter Shank, requires SAD375R1 spindle adapter or to be used with collet holder



CDR343 Combo Core drill / Reamer

.343" Pilot to bore for standard 1/2" OD valve guide insert with .375" diameter Shank, requires SAD375R1 spindle adapter or to be used with collet holder



CDR375 Combo Core drill / Reamer

.375" Pilot to bore for standard 1/2" OD valve guide insert with .375" diameter Shank, requires SAD375R1 spindle adapter or to be used with collet holder



VSD100-KIT Valve Seat Driver Kit

Includes Seat Driver Body (VSD101) 5 Dual seat Ring Adapters (VSD102 1 - 1.1/8", VSD103 1.1/4 - 1.3/8", VSD104 1.1/2 - 1.5/8", VSD105 1.3/4 - 1.7/8", VSD106 2 - 2.1/8"), 5 Solid Tapered Pilots STP0250, STP0275, STP0312, STP0343, STP0374



VGD-KIT Valve Guide Driver Kit

Includes .312" Valve Guide Driver, .343" Valve Guide Driver, .372" Valve Guide Driver and 7.0mm Valve Guide Driver (requires air hammer - not available from Rottler)



VGTC-KIT3 Valve Guide Top Cutter Kit

With 1/2" straight Shank. To be used with Collet holder or SAD500R1 Spindle Adapter. Kit includes 5/16", 11/32" & 3/8" pilot for guide top cutter



Fixed Double Insert Milling Heads

FMH Fixed Double Replaceable Insert Milling Heads - Bore diameter 1.25 - 2.50" (31.75 - 63.50mm) available in increments of 1/16" (.125") (Requires Milling Head driver) (specify size)

FMH1000R1 1.0000" Fixed Double Replaceable Insert Milling Head

With .562" Driver (Requires BD560 .562" ID Milling head Driver)



FMH10625R1 1.0625" Fixed Double Replaceable Insert Milling Head

With .562" Driver ID (Requires BD560 .562" ID Milling head Driver)



FMH11250R1 1.1250" Fixed Double Replaceable Insert Milling Head

With .562" Driver ID (Requires BD560 .562" ID Milling head Driver)



FMH11875R1 1.1875" Fixed Double Replaceable Insert Milling Head

With .562" Driver ID (Requires BD560 .562" ID Milling head Driver)



FMH13125R1 1.3125" Fixed Double Replaceable Insert Milling Head

With .562" Driver ID (Requires BD560 .562" ID Milling head Driver)



FMH13750R1 1.3750" Fixed Double Replaceable Insert Milling Head

With .562" Driver ID (Requires BD560 .562" ID Milling head Driver)



FMH14375R1 1.4375" Fixed Double Replaceable Insert Milling Head

With .562" Driver ID (Requires BD560 .562" ID Milling head Driver)

**FMH15000R1 1.5000" Fixed Double Replaceable Insert Milling Head**

With .562" Driver ID (Requires BD560 .562" ID Milling head Driver)

**FMH15625R1 1.5625" Fixed Double Replaceable Insert Milling Head**

With .562" Driver ID (Requires BD560 .562" ID Milling head Driver)

**FMH16250R1 1.6250" Fixed Double Replaceable Insert Milling Head**

With .562" Driver ID (Requires BD560 .562" ID Milling head Driver)

**FMH16875R1 1.6875" Fixed Double Replaceable Insert Milling Head**

With .562" Driver ID (Requires BD560 .562" ID Milling head Driver)

**FMH17500R1 1.7500" Fixed Double Replaceable Insert Milling Head**

With .562" Driver ID (Requires BD560 .562" ID Milling head Driver)



FMH18125R1 1.8125" Fixed Double Replaceable Insert Milling Head

With .562" Driver ID (Requires BD560 .562" ID Milling head Driver)



FMH18750R1 1.8750" Fixed Double Replaceable Insert Milling Head

With .562" Driver ID (Requires BD560 .562" ID Milling head Driver)







FMH20000R1 2.0000" Fixed Double Replaceable Insert Milling Head

With .562" Driver ID (Requires BD560 .562" ID. Ball Head Milling head Driver)

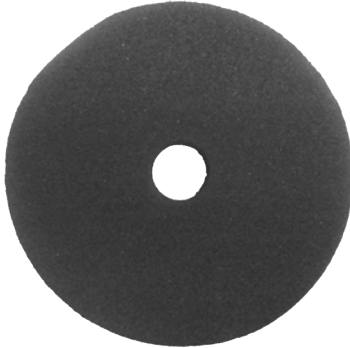
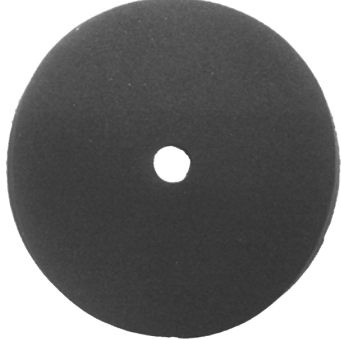
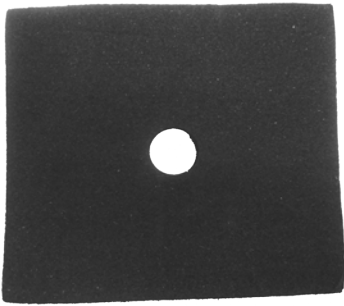
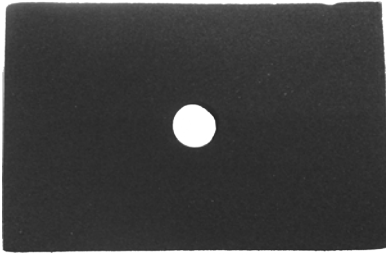
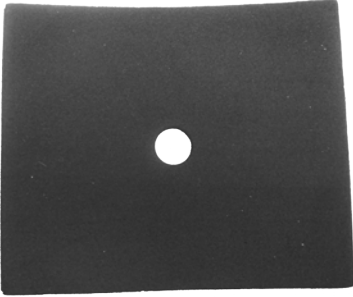

Consumable Parts for Seat and Guide Models

<p>SLEEVER1 Spindle Adapter Replacement Sleeve</p> 	<p>BSW002 Diamond Wheel Cutting Bit Sharpener replacement Wheel (3.000" Diameter OD by .375" ID)</p> 	<p>VT-FP1562 Replacement Foam Pad For Round Vacuum Pad 1.562" (39.675mm) diameter</p> 
<p>VT-FP1875 Replacement Foam Pad For Round Vacuum Pad 1.875" (47.625mm) diameter</p> 	<p>VT-FP2125 Replacement Foam Pad For Round Vacuum Pad 2.125" (53.975mm) diameter</p> 	<p>VT-FP3125 Replacement Foam Pad For Round Vacuum Pad 3.125" (79.375mm) diameter</p> 
<p>VT-FP25X22 Replacement Foam Pad For Square Vacuum Pad 2.500 X 2.250" (63.5 X 57.15mm) square</p> 	<p>VT-FP31X20 Replacement Foam Pad For Square Vacuum Pad 3.125 X 2.000" (79.375 X 50.8mm) square</p> 	<p>VT-FP33X27 Replacement Foam Pad For Square Vacuum Pad 3.375 X 2.750" (85.725 X 69.85mm) square</p> 

<p>PRW600PIN Replaceable Pin For PRW600 Pilot Removable wrench tool</p> 	<p>PRW375PIN Replaceable Pin For PRW375 Pilot Removable wrench tool</p> 	<p>PRW20PIN Replaceable Pin For PRW375 Pilot Removable wrench tool</p> 
<p>511-29-12E Torx Screw M2.5 X 0.45 (straight angle insert holders only)</p> 	<p>T7D T7 Torx Driver For 1/4" insert (straight angle insert holders only)</p> 	
<p>T8S T8 Torx Tip Holding Screws</p> 	<p>T15S T15 Torx Tip Holding Screws</p> 	<p>S1032-250 BH375R1 and BH600R1 Tip Holder Locking Screw 10/32" X 1/4" (requires 2)</p> 
<p>S250-28-250 BH375WR1 Tip Holder Locking Screw 1/4"-28" X 1/4" (requires 2)</p> 	<p>S1032-437 TH1999 Adjusting Screw (10/32 X 7/16")</p> 	<p>S1032-375 TH2000 Adjusting Screw (10/32 X 3/8")</p> 
<p>S1032-500 TH2001 Adjusting Screw (10/32 X 1/2")</p> 	<p>S1032-625 TH2002 Adjusting Screw (10/3" X 5/8")</p> 	<p>S500-1600 TH2003 Adjusting Screw (6.00 X 16mm)</p> 
<p>S600-2015 TH2004 Adjusting Screw (6.00 X 20.15mm)</p> 	<p>ICC003 Insert, Indexable Carbide For Fixed milling heads - large size - for 1.562" and larger cutters</p> 	<p>ICC002 Insert, Indexable Carbide For Fixed milling heads - small size - for 1.250 - 1.500" cutters</p> 

Optional Fixtures

PER-FIX Pneumatic Quick Clamping Production Fixture

Allows the cylinder head to be clamped upwards against stops with air pressure - the cylinder head is simply pushed back into the fixture and the clamping is automatic.

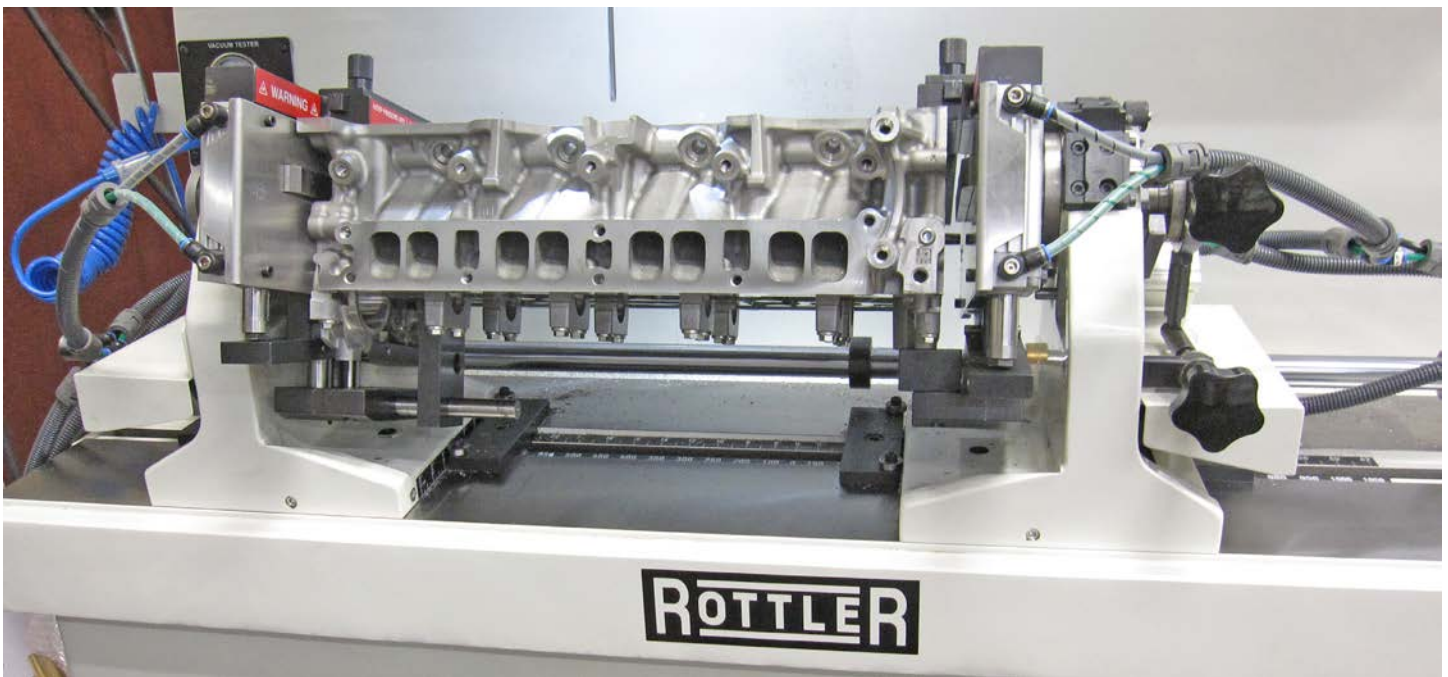

STD-FIX Universal Heavy Duty Bolt Down 360 degree Roll Over Cylinder Head Fixture

Roll-over fixture air floats on table which makes multi valve set up-very easy.

