

ROTTLER

SG7MTS OPTIONAL EQUIPMENT CATALOG

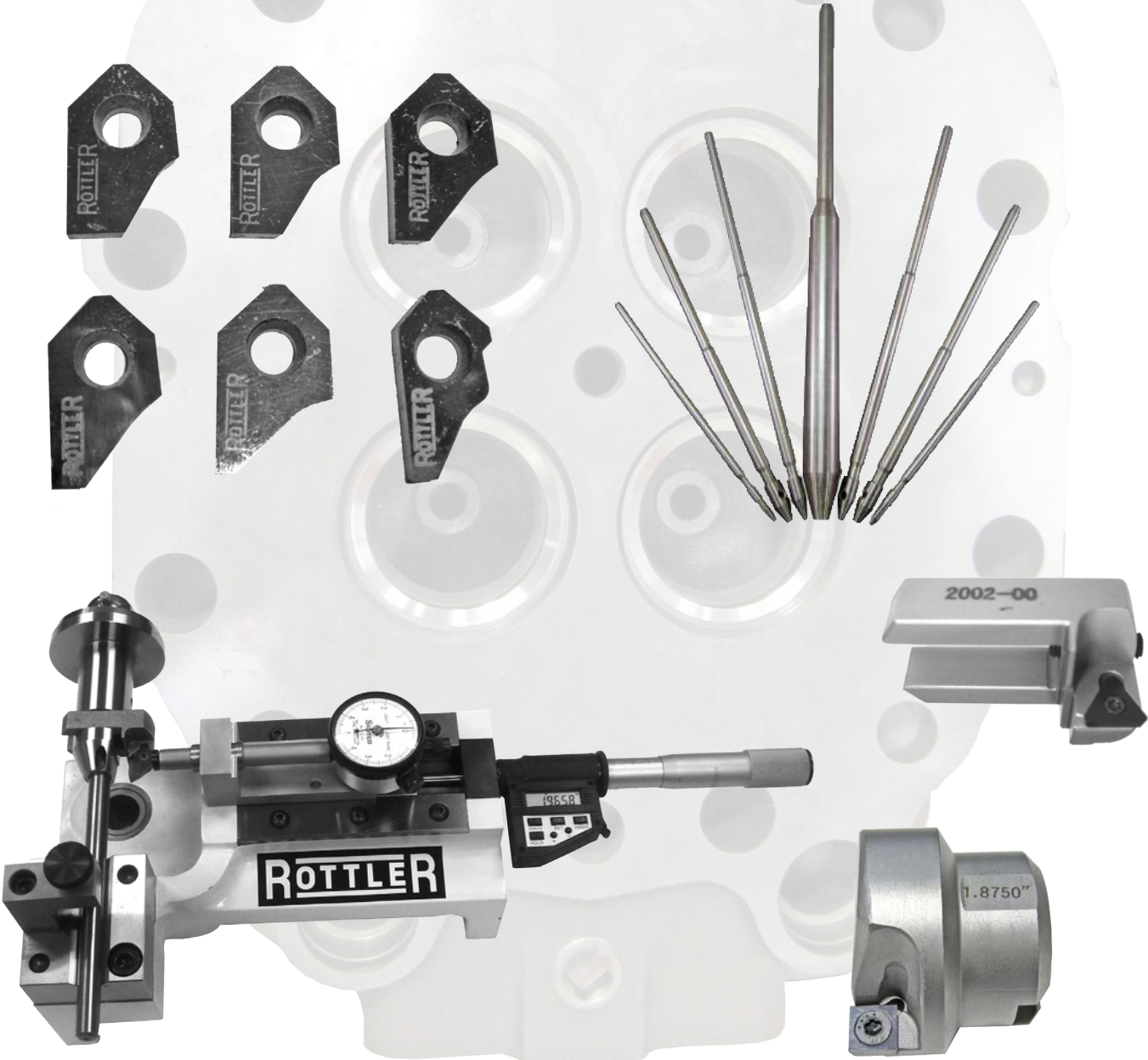

ORDERING PROCEDURE

Contact your regional Rottler sales rep for assistance in ordering optional equipment, replacement parts, or tooling.

If you are unable to contact your regional Rottler sales rep, call the factory at 253-872-7050 and ask to speak to the parts sales specialist.

Have the following information handy to expedite the ordering process:

1. Your name, business name, and contact number
2. Customer number
3. If you don't have a customer number, your billing address
4. Shipping address if different from billing address
5. Machine model and serial number
6. Part number and description of what you want to order
7. Preferred method of shipment

You may also contact us via e-mail with the above information. Send e-mail requests to:
parts@rottermfg.com

In some cases you may be requested to send a photo of the part you are ordering if it is a replacement part, or doesn't appear in the database.

If you are unsure which part you need to order, contact our service department and ask to speak to one of our service consultants. They will assist you in determining which part you require.

THERE IS A MINIMUM ORDER OF \$25.00



Contents

Spherical Self Aligning Spindle Adapters	1
RBHAR1 Rottler Spring Free Spherical Self Aligning Spindle Adapter	1
Rottler R1 Spindle Adapters	1
SAD500R1 Spindle Adapter	1
SAD375R1 Spindle Adapter	1
PC375R1 Universal Three Jaw Chuck	1
COLLET-KITR1	2
Tool Holders	3
BH375WR1 Spring-Free Spherical Tool Holder	3
BH375R1 Spring-Free Spherical Tool Holder.....	3
BH375-2R1 Spring-Free Spherical Tool Holder 2" LONG	3
BH600R1 Spring-Free Spherical Tool Holder.....	3
BD105 Spherical Driver.....	4
BD560 Spherical Driver.....	4
Tip Holders for Valve Seat Angle Cutting.....	4
TH1999 Tip Holder	4
TH2000 Tip Holder	4
TH2001 Tip Holder	5
TH2002 Tip Holder	5
TH2003 Tip Holder	5
TH2004 Tip Holder	5
TH2005 Tip Holder	5
Triangular Insert Tip Holders.....	6
TH2000-00 00 Degree Triangular Tip Holder	6
TH2001-00 00 Degree Triangular Tip Holder	6
TH2002-00 00 Degree Triangular Tip Holder	6
TH2003-00 00 Degree Triangular Tip Holder	6
TH2004-00 00 Degree Triangular Tip Holder	7
TH2005-00 00 Degree Triangular Tip Holder	7
Triangular Insert Holders	7
TH2002-20 20 Degree Triangular Tip Holder	7
TH2002-30 30 Degree Triangular Tip Holder	7
TH2002-45 45 Degree Triangular Tip Holder	8
TH2003-20 20 Degree Triangular Tip Holder	8

TH2003-30 30 Degree Triangular Tip Holder	8
TH2003-45 45 Degree Triangular Tip Holder	8
TH2004-20 20 Degree Triangular Tip Holder	9
TH2004-30 30 Degree Triangular Tip Holder	9
TH2004-45 45 Degree Triangular Tip Holder	9
TH2005-20 20 Degree Triangular Tip Holder	9
TH2005-30 30 Degree Triangular Tip Holder	10
TH2005-45 45 Degree Triangular Tip Holder	10
Triangular Inserts and Torx Driver for the Previous Insert Holders	10
RT211 Triangular Insert.....	10
RT212 Triangular Insert.....	10
Suggested Basic Tooling.....	11
PRW375 Pilot Removal Wrench	11
PRW600 Pilot Removable Wrench	11
T8D T8 Torx Tip Holding Screw Driver	11
T7D T7 Torx Driver.....	11
ALLEN-KEYS-IN.....	11
ALLEN-KEYS-MM	11
Micrometers Setting Fixtures and Measurement Tools	12
DSP Tool setting Device with Interchangeable Point.....	12
BM Boring Micrometer, Digital Reading Inch and Metric.....	12
6-1SETTINGFIX	13
VSG102-375 Precision Valve Seat Concentricity Gage Base Only	13
VSG102-6MM Precision Valve Seat Concentricity Gage Base Only	14
502-11-39L Mechanical Run Out Indicator	14
502-11-39D Mechanical run out indicator.....	14
Fixtures.....	15
CANTEDFIX.....	15
CUTTING INSERTS	16
Cutting Insert Sharpener for Multi Angle Inserts	16
BWS02 Diamond Wheel Cutting Bit Sharpener - Single Wheel	16
Automotive Import, Domestic and Diesel Inserts.....	17
Suggested 45 Degree Seat Inserts.....	17
RCA001 Carbide Seat Insert.....	17
RCA004 Carbide Seat Insert.....	17
RCA005 Carbide Seat Insert.....	17
RCA007 Carbide Seat Insert.....	17



RCA014 Carbide Seat Insert 17

RCA026 Carbide Seat Insert 17

Suggested 30 Degree Seat Inserts..... 18

RCA301 Carbide Seat Insert 18

RCA303 Carbide Seat Insert 18

RCA307 Carbide Seat Insert 18

RCA348 Carbide Seat Insert 18

Suggested 37.5 Degree Seat Inserts..... 19

RCA401 Carbide Seat Insert 19

Suggested Straight Angle Seat Inserts 19

RCA511 Carbide Seat Insert 19

RCA512 Carbide Seat Insert 19

RCA513 Carbide Seat Insert 19

RCA501 Carbide Seat Insert 20

RCA521 Carbide Seat Insert 20

RCA502 Carbide Seat Insert 20

RCA503 Carbide Seat Insert 20

RCB506 Carbide Seat Insert 20

Suggested 45 Degree Seat Inserts for Multi-Valves Cylinder Heads..... 21

RCA632 Carbide Seat Insert 21

RCA637 Carbide Seat Insert 21

High Performance Inserts..... 22

RCB605 Carbide Seat Insert 22

RCB607 Carbide Seat Insert 22

RCB608 Carbide Seat Insert 22

RCA614 Carbide Seat Insert 22

RCB620 Carbide Seat Insert 23

RCB621 Carbide Seat Insert 23

RCA623 Carbide Seat Insert 23

Harley Davidson Inserts..... 24

RCA626 Carbide Seat Insert 24

RCA633 Carbide Seat Insert 24

RCA640 Carbide Seat Insert 24

Counterboring and Straight Angles Inserts 24

RCA511 Carbide Seat Insert 24

RCA512 Carbide Seat Insert 24

RCA513 Carbide Seat Insert 24

RT211 Insert, triangular..... 25

RT212 Insert, triangular 25

Rottler Special Profile Cutter Inserts Policy 25

Available Carbide Pilots by Diameter and Length.....	26
Miscellaneous Tooling	27
CDR312 Combo Core drill / Reamer	27
CDR343 Combo Core drill / Reamer	27
CDR375 Combo Core drill / Reamer	27
VSD100-KIT Valve Seat Driver Kit	28
VGD-KIT Valve Guide Driver Kit	29
VGTC-KIT3 Valve Guide Top Cutter Kit	29
Fixed Double Insert Milling Heads	30
FMH10000R1 1.0000" Fixed Double Replaceable Insert Milling Head.....	30
FMH10625R1 1.0625" Fixed Double Replaceable Insert Milling Head.....	30
FMH11250R1 1.1250" Fixed Double Replaceable Insert Milling Head.....	30
FMH11875R1 1.1875" Fixed Double Replaceable Insert Milling Head.....	30
FMH13125R1 1.3125" Fixed Double Replaceable Insert Milling Head.....	30
FMH13750R1 1.3750" Fixed Double Replaceable Insert Milling Head.....	30
FMH14375R1 1.4375" Fixed Double Replaceable Insert Milling Head.....	31
FMH15000R1 1.5000" Fixed Double Replaceable Insert Milling Head.....	31
FMH15625R1 1.5625" Fixed Double Replaceable Insert Milling Head.....	31
FMH16250R1 1.6250" Fixed Double Replaceable Insert Milling Head.....	31
FMH16875R1 1.6875" Fixed Double Replaceable Insert Milling Head.....	31
FMH17500R1 1.7500" Fixed Double Replaceable Insert Milling Head.....	31
FMH18125R1 1.8125" Fixed Double Replaceable Insert Milling Head.....	32
FMH18750R1 1.8750" Fixed Double Replaceable Insert Milling Head.....	32
FMH20000R1 2.0000" Fixed Double Replaceable Insert Milling Head.....	32
Consumable Parts for Seat and Guide Models.....	33
SLEEVE1 Spindle Adapter Replacement Sleeve	33
BSW002 Diamond Wheel	33
VT-FP1562 Replacement Foam Pad.....	33
VT-FP1875 Replacement Foam Pad.....	33
VT-FP2125 Replacement Foam Pad.....	33
VT-FP3125 Replacement Foam Pad.....	33
VT-FP25X22 Replacement Foam Pad	33
VT-FP31X20 Replacement Foam Pad	33
VT-FP33X27 Replacement Foam Pad	33
PRW600PIN Replaceable Pin.....	34
PRW375PIN Replaceable Pin.....	34
PRW20PIN Replaceable Pin.....	34
511-29-12E Torx Screw.....	34
T7D T7 Torx Driver.....	34



T8S T8 Torx Tip Holding Screws	34
T15S T15 Torx Tip Holding Screws	34
S1032-250 BH375R1 and BH600R1 Tip Holder Locking Screw	34
S250-28-250 BH375WR1 Tip Holder Locking Screw	34
S1032-437 TH1999 Adjusting Screw	34
S1032-375 TH2000 Adjusting Screw	34
S1032-500 TH2001 Adjusting Screw	34
S1032-625 TH2002 Adjusting Screw	34
S500-1600 TH2003 Adjusting Screw	34
S600-2015 TH2004 Adjusting Screw	34
ICC003 Insert, Indexable Carbide	34
ICC002 Insert, Indexable Carbide	34

Spherical Self Aligning Spindle Adapters

RBHAR1 Rottler Spring Free Spherical Self Aligning Spindle Adapter

Patented for Rottler R1 Spindle Taper for 1.000: Diameter Spherical heads, for .375" and 6.00mm tooling



Rottler R1 Spindle Adapters

SAD500R1 Spindle Adapter

For Rottler R1 Spindle Taper for 1/2" (12.70mm) Shank Diameter Tools, reamers, drills, etc includes two locking set screws



SAD375R1 Spindle Adapter

For Rottler R1 Spindle Taper for 3/8" (9.525mm) Shank Diameter Tools, reamers, drills, etc includes two locking set screws

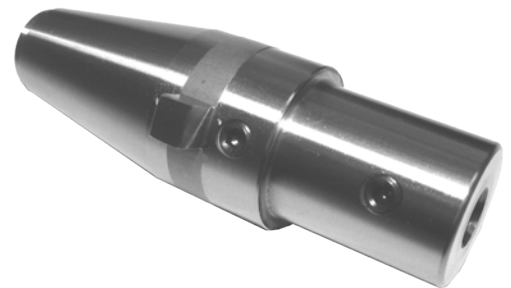

PC375R1 Universal Three Jaw Chuck

Including Spindle Adapter for Rottler R1 Spindle Taper



COLLET-KITR1

Collet chuck set of (8) collets Includes: 3/16, 7/32, 1/4, 5/16, 11/32, 3/8, 7/16, 1/2" (4.775, 5.556, 6.35, 7.938, 8.731, 9.525, 11.113, 12.7mm) Spring Collets, Collet Chuck Spindle Adapter with Collet Nut for Rottler R1 Spindle Taper and Spanner Wrench for Collet Chuck



Tool Holders

BH375WR1 Spring-Free Spherical Tool Holder

For use w/ TH2003, TH2004 & TH2005 Tip Holders. Range: 1.570 - 4.724"
(40 - 120mm) Used with RBHAR1 Spindle Adapter"



BH375R1 Spring-Free Spherical Tool Holder

For use w/ TH2000, TH2001, TH2002 Tip Holders. Range: .750 - 2.360"
(20 - 60mm) Used with RBHAR1 Spindle Adapter"

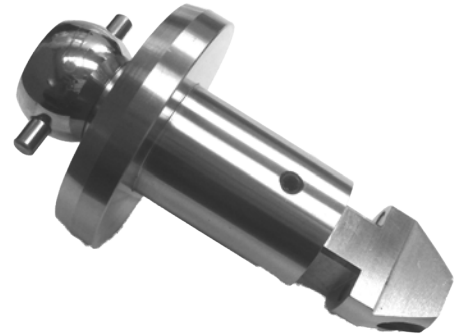

BH375-2R1 Spring-Free Spherical Tool Holder 2" LONG

For use w/ TH2000, TH2001, TH2002 Tip Holders. Range:
.750 - 2.360" (20 - 60mm) Used with RBHAR1 Spindle
Adapter (FOR HARLEY DAVIDSON SHOVEL SEATS
APPLICATIONS)



BH600R1 Spring-Free Spherical Tool Holder

For use w/ TH1999 Tip Holder and 6.00mm Shank Pilots. Range: .551 - .984" (14 - 25mm)
for 6.00mm Shank Carbide Pilots. Used with RBHAR1 Spindle Adapter"



BD105 Spherical Driver

For Fixed Size and Adjustable Valve Seat Installation Counterbore Cutters for .625" I.D.
Cutter Bodies Used with RBHAR1 Spindle Adapter



BD560 Spherical Driver

For Fixed Size and Adjustable Valve Seat Installation Counterbore Cutters for .562" I.D.
Cutter Bodies Used with RBHAR1 Spindle Adapter



Tip Holders for Valve Seat Angle Cutting

TH1999 Tip Holder

Range using the BH600-R1: .570 - 1.250" (14.48 - 33.52mm) (Using RCA630 Cutting Insert for minimum range) Range with BH375R1: .800 - 1.320" (20.32 - 33.52mm Using RCA630 Cutting Insert for minimum range)

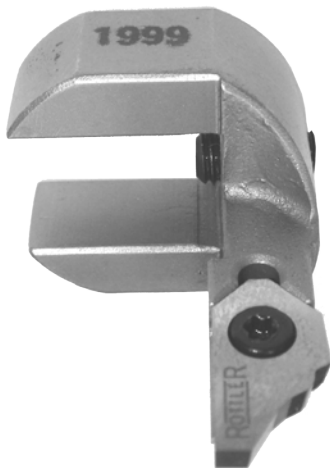

TH2000 Tip Holder

Range using the BH600-R1: .597 - 1.180" (15.16 - 30mm) (Using RCA630 Cutting Insert for minimum range) Range with BH375R1: .800 - 1.395" (20.32 - 35.43mm Using RCA630 Cutting Insert for minimum range)

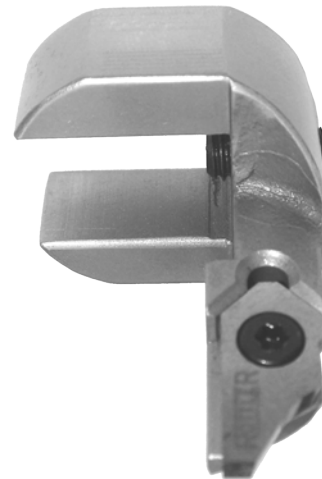

TH2001 Tip Holder

Range using the BH600-R1: .850 - 1.625" (21.6 - 41.3mm) (Using RCA630 Cutting Insert for minimum range) Range with BH375R1: 1.00 - 1.800" (25.4 - 35.4mm Using RCA630 Cutting Insert for minimum range)

**TH2002 Tip Holder**

Range using the BH600-R1: 1.200 - 2.360" (30.48 - 60.0mm) (Using RCA630 Cutting Insert for minimum range) Range with BH375R1: 1.270 - 2.360" (32.26 - 59.94mm Using RCA630 Cutting Insert for minimum range)

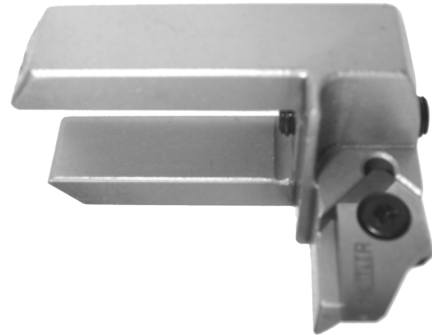
**TH2003 Tip Holder**

Range: 1.270 - 2.360" (32.26 - 60mm) (Using RCA630 Cutting Insert for minimum range) for BH375WR1 Tool holder Only.

**TH2004 Tip Holder**

Range: 1.850 - 3.150" (47 - 80mm) (Using RCA630 Cutting Insert for minimum range) for BH375WR1 Tool holder Only.

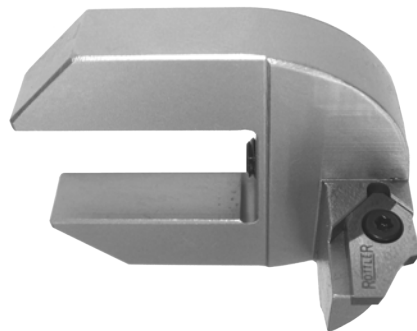
**TH2005 Tip Holder**

Range: 2.625 - 4.724" (66.7 - 120mm) (Using RCA630 Cutting Insert for minimum range) for BH375WR1 Tool holder Only.



Triangular Insert Tip Holders

For Valve Seat Installation Counterboring for RT211 (1/4" I.C.) Rottler Triangular Insert Only

TH2000-00 00 Degree Triangular Tip Holder

For Valve Seat Installation Counterboring. Uses RT211, 1/4" IC Triangular Insert. Requires BH375R1 Self Aligning Tool holder. Range with BH600R1: 1.055 - 1.400" (26.797 - 26.8mm). Range with BH375R1: 1.27 - 1.58" (32.258 - 40.132mm)



TH2001-00 00 Degree Triangular Tip Holder

For Valve Seat Installation Counterboring. Uses RT211 (1/4" I.C.) Triangular Insert. Requires BH375R1 Self Aligning Tool holder. Range: 1.100 - 1.570" (28 - 42mm)



TH2002-00 00 Degree Triangular Tip Holder

For Valve Seat Installation Counterboring. Uses RT211 (1/4" I.C.) Triangular Insert. Requires BH375R1 Self Aligning Tool holder. Range: 1.570 - 2.360" (40 - 60mm)

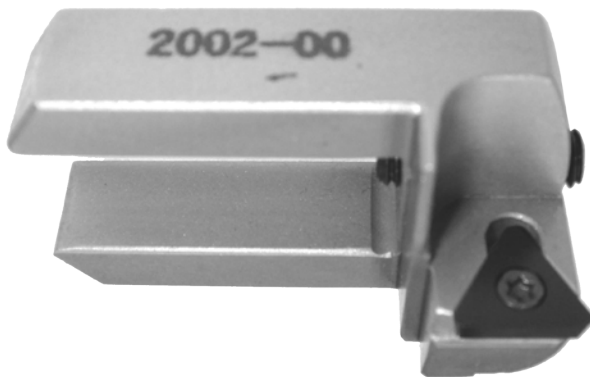

TH2003-00 00 Degree Triangular Tip Holder

For Valve Seat Installation Counterboring. Uses RT211 (1/4" I.C.) Triangular Insert. Requires BH375WR1 Self Aligning Tool holder. Range: 1.570 - 2.360" (40 - 60mm)



TH2004-00 00 Degree Triangular Tip Holder

For Valve Seat Installation Counterboring. Uses RT211 (1/4" I.C.) Triangular Insert. Requires BH375WR1 Self Aligning Tool holder. Range: 2.280 - 3.150" (58 - 80mm)

**TH2005-00 00 Degree Triangular Tip Holder**

For Valve Seat Installation Counterboring. Uses RT211 (1/4" I.C.) Triangular Insert. Requires BH375WR1 Self Aligning Tool holder. Range: 3.071 - 4.724" (78 - 120mm)

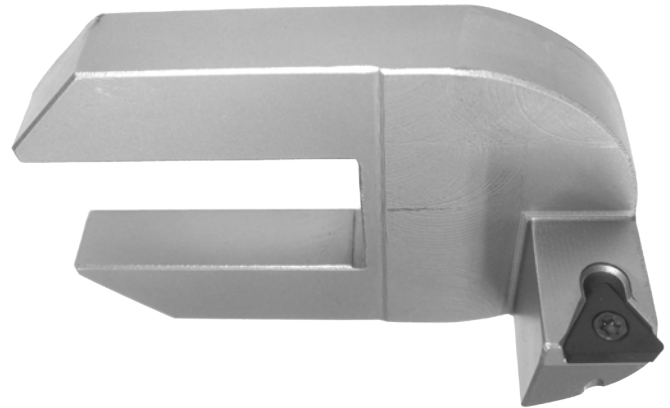
**Triangular Insert Holders**

For Single Angle Valve Seat Cutting for RT211 (1/4" I.C.) Rottler Triangular Insert Only

TH2002-20 20 Degree Triangular Tip Holder

For 20 Degree Valve Seat Angle Cutting. Uses RT211 (1/4" I.C.) Triangular Insert. Requires BH375R1 Self Aligning Tool holder. Range: 1.570 - 2.360" (40 - 60mm)

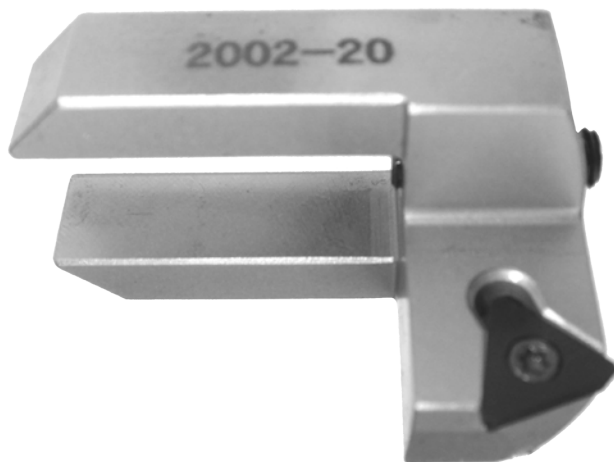
**TH2002-30 30 Degree Triangular Tip Holder**

For 30 Degree Valve Seat Angle Cutting. Uses RT211 (1/4" I.C.) Triangular Insert. Requires BH375R1 Self Aligning Tool holder. Range: 1.570 - 2.360" (40 - 60mm)

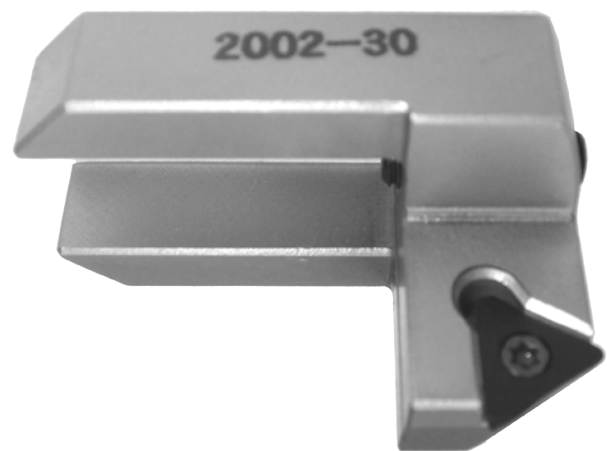

TH2002-45 45 Degree Triangular Tip Holder

For 45 Degree Valve Seat Angle Cutting. Uses RT211 (1/4" I.C.) Triangular Insert. Requires BH375R1 Self Aligning Tool holder. Range: 1.570 - 2.360" (40 - 60mm)

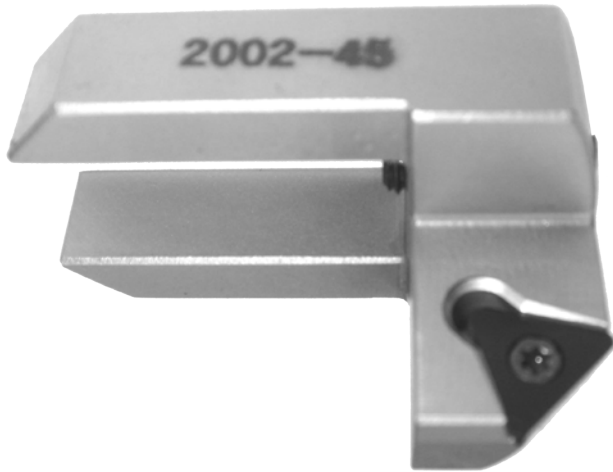
**TH2003-20 20 Degree Triangular Tip Holder**

For Valve Seat Angle Cutting. Uses RT211 (1/4" I.C.) Triangular Insert. Requires BH375WR1 Self Aligning Tool holder. Range: 1.570 - 2.360" (40 - 60mm)

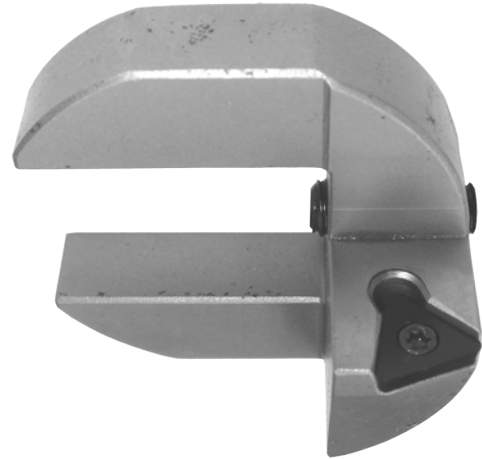
**TH2003-30 30 Degree Triangular Tip Holder**

For Valve Seat Angle Cutting. Uses RT211 (1/4" I.C.) Triangular Insert. Requires BH375WR1 Self Aligning Tool holder. Range: 1.570 - 2.360" (40 - 60mm)

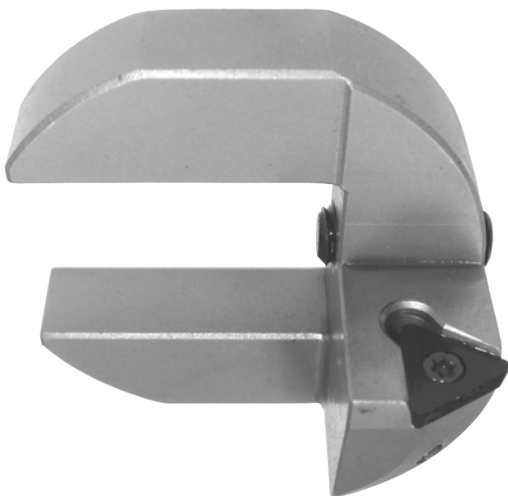
**TH2003-45 45 Degree Triangular Tip Holder**

For Valve Seat Angle Cutting. Uses RT211 (1/4" I.C.) Triangular Insert. Requires BH375WR1 Self Aligning Tool holder. Range: 1.570 - 2.360" (40 - 60mm)

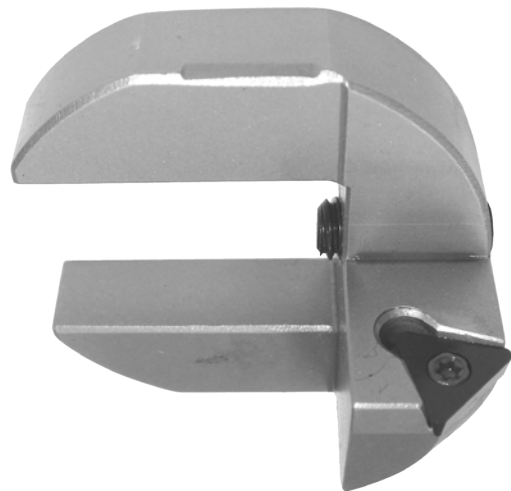

TH2004-20 20 Degree Triangular Tip Holder

For Valve Seat Angle Cutting. Uses RT211 (1/4" I.C.) Triangular Insert. Requires BH375WR1 Self Aligning Tool holder. Range: 2.280 - 3.150" (58 - 80mm)

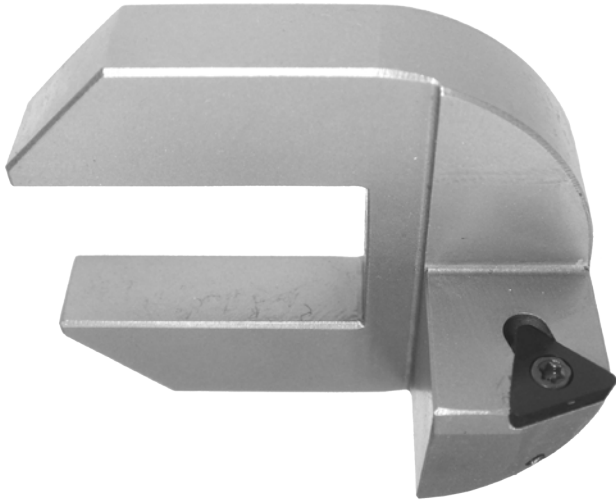
**TH2004-30 30 Degree Triangular Tip Holder**

For Valve Seat Angle Cutting. Uses RT211 (1/4" I.C.) Triangular Insert. Requires BH375WR1 Self Aligning Tool holder. Range: 2.280 - 3.150" (58 - 80mm)

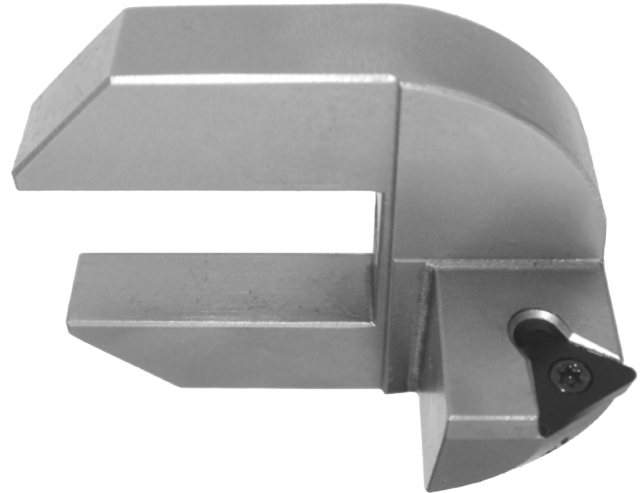
**TH2004-45 45 Degree Triangular Tip Holder**

For Valve Seat Angle Cutting. Uses RT211 (1/4" I.C.) Triangular Insert. Requires BH375WR1 Self Aligning Tool holder. Range: 2.280 - 3.150" (58 - 80mm)

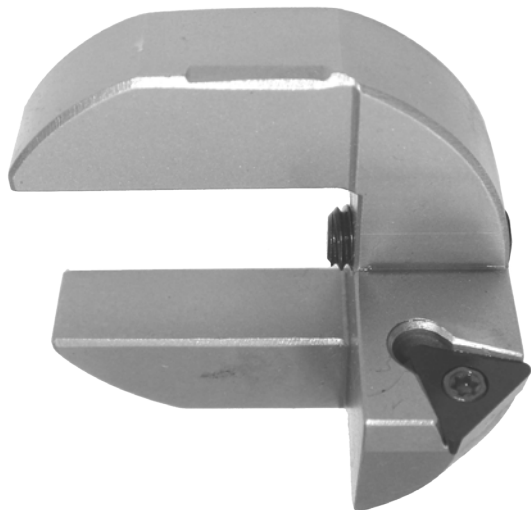
**TH2005-20 20 Degree Triangular Tip Holder**

For Valve Seat Angle Cutting. Uses RT211 (1/4" I.C.) Triangular Insert. Requires BH375WR1 Self Aligning Tool holder. Range: 3.071 - 4.724" (78 - 120mm)

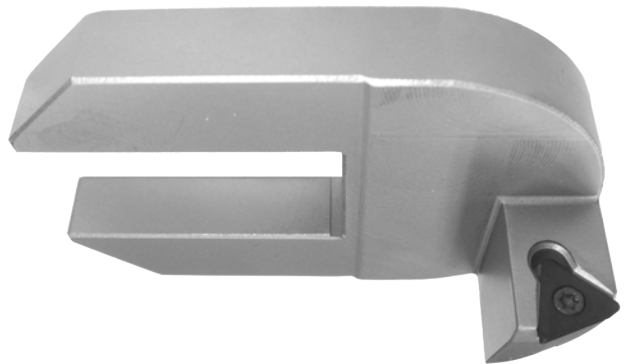

TH2005-30 30 Degree Triangular Tip Holder

For Valve Seat Angle Cutting. Uses RT211 (1/4" I.C.)
Triangular Insert. Requires BH375WR1 Self Aligning Tool
holder. Range: 3.071 - 4.724" (78 - 120mm)

TH2005-45 45 Degree Triangular Tip Holder

For Valve Seat Angle Cutting. Uses RT211 (1/4" I.C.)
Triangular Insert. Requires BH375WR1 Self Aligning Tool
holder. Range: 3.071 - 4.724" (78 - 120mm)

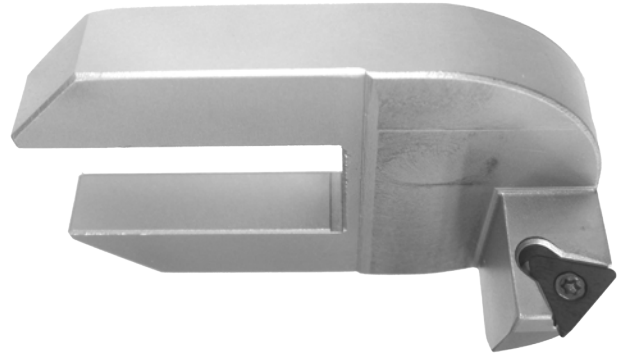
Triangular Inserts and Torx Driver for the Previous Insert Holders
RT211 Triangular Insert

1/4" (6.35mm) I.C., 1/64" radius FOR COUNTERBORING
and SINGLE ANGLE INSERT HOLDERS

RT212 Triangular Insert

1/4" (6.35mm) I.C., 1/32" radius FOR COUNTERBORING
and SINGLE ANGLE INSERT HOLDERS



Suggested Basic Tooling

<p>PRW375 Pilot Removal Wrench For .375" (9.522mm) pilot shank</p> 	<p>PRW600 Pilot Removable Wrench For 6.00mm shank pilot</p> 
<p>T8D T8 Torx Tip Holding Screw Driver</p> 	<p>T7D T7 Torx Driver For RT211 & RT212 (1/4" I.C.) insert</p> 
<p>ALLEN-KEYS-IN Inch Ball end hex Allen Key Set Drivers From: 1/16 - 3/8"</p> 	<p>ALLEN-KEYS-MM Metric Ball end hex Allen Key Set</p> 

Micrometers Setting Fixtures and Measurement Tools

DSP Tool setting Device with Interchangeable Point



BM Boring Micrometer, Digital Reading Inch and Metric

(.800 - 2.80") with setting standard for .375" (9.52mm) and 6.00mm (152.40mm) shank diameter



6-1SETTINGFIX

Six in one measuring Fixture (Pilot OD, Valve Stem OD, Set diameter on profile inserts, Setting 90 degree counterboring inserts, Set adjustable milling head cutters, Check alignment on valve stem and check roundness on valve stems.

**VSG102-375 Precision Valve Seat Concentricity Gage Base Only**

For .375" Pilot Shank (Must Order dial indicator .0001" or .002mm Metric indicator)

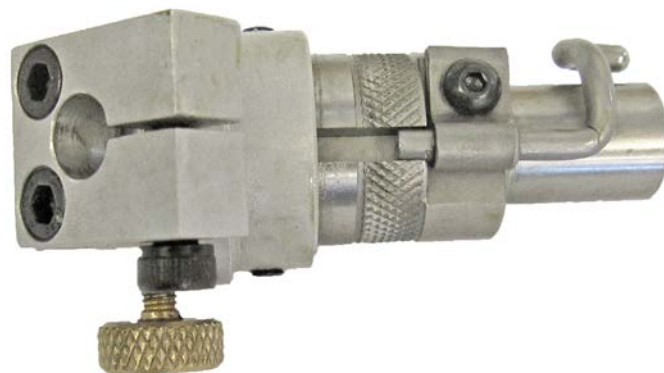

VSG102-6MM Precision Valve Seat Concentricity Gage Base Only

For 6.00mm Pilot Shank, Base Only (Must Order dial indicator .0001" or .002mm Metric indicator)

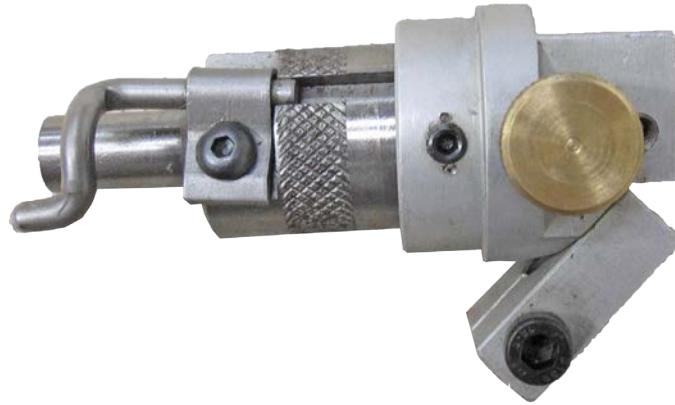

502-11-39L Mechanical Run Out Indicator

For precision bore adjustment (.002mm resolution)
METRIC



502-11-39D Mechanical run out indicator

For Precision bore adjustment (.0001" resolution) INCH



Fixtures

CANTEDFIX

Canted Fixture for leveling Canted cylinder heads on any fixed pilot Seat and Guide Machine

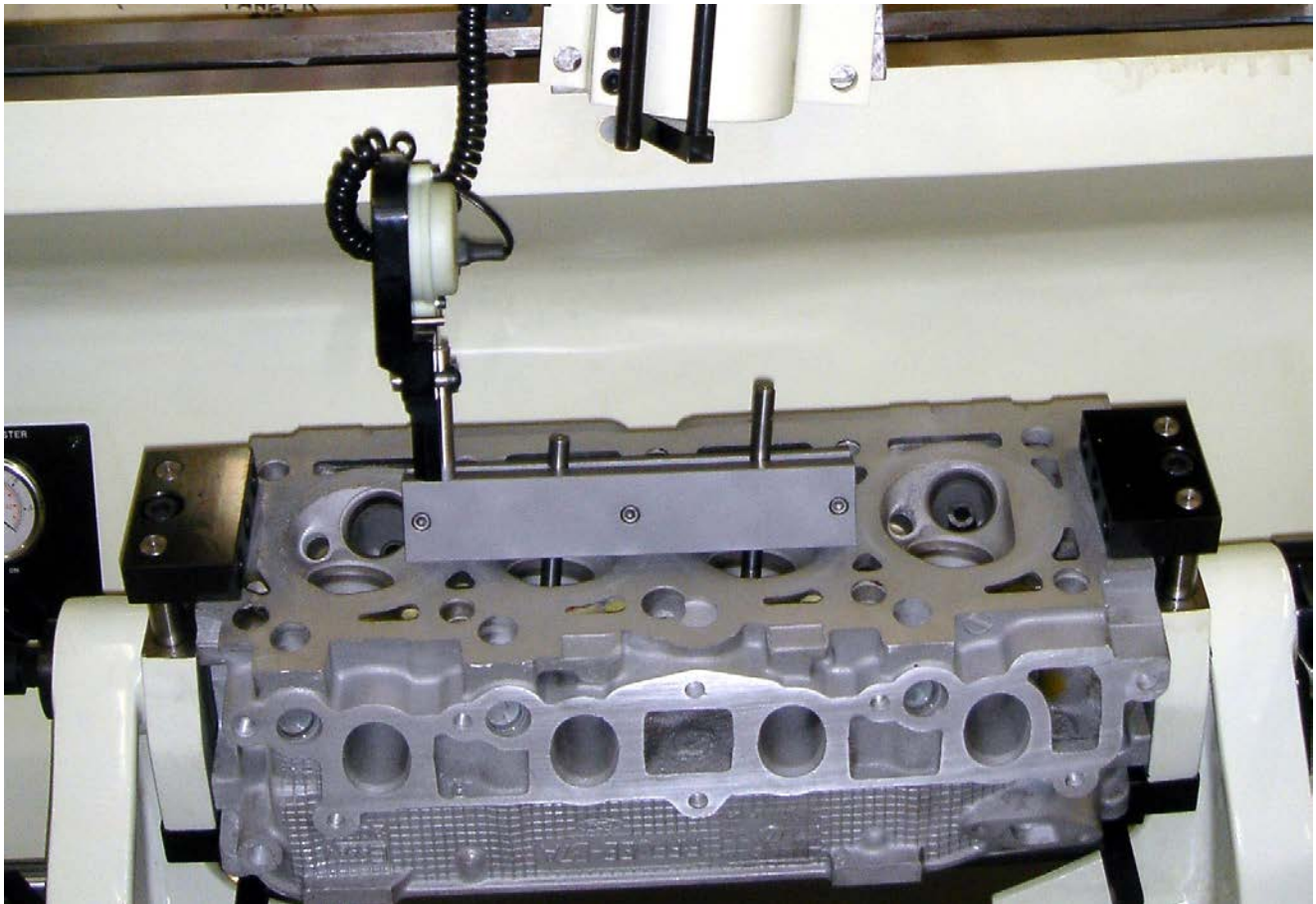

CUTTING INSERTS

NOTE: For Recommended Inserts, see Inserts and Profile Catalog

Select the correct Insert profile to match the original factory valve seat shape. The relief angle and the seating surface width and angle must match.

All specifications can be obtained from the original manufacturer's manual.

Select the proper Insert base on the application RCA insert profiles are design for regular three angle seat profiles, make sure the that top angle will not go over the seat insert,

RCB inserts Profiles are design for a multiple angles and radius and is recommended for High performance profiles.

Cutting Insert Sharpener for Multi Angle Inserts

BWS02 Diamond Wheel Cutting Bit Sharpener - Single Wheel



Automotive Import, Domestic and Diesel Inserts

Suggested 45 Degree Seat Inserts

NOTE: Orders of 20+ of the same RCA insert receive 10% discount. Orders of 50+ of the same RCA insert receive 20% discount. Does not apply to mix-and-match orders.

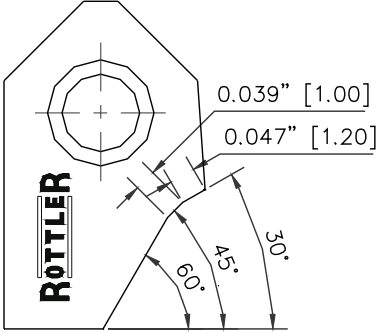
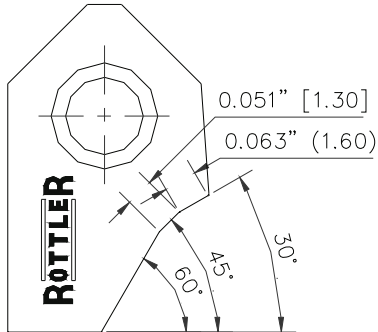
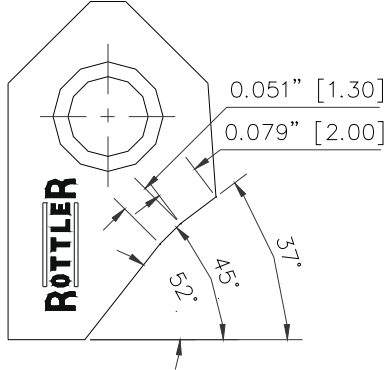
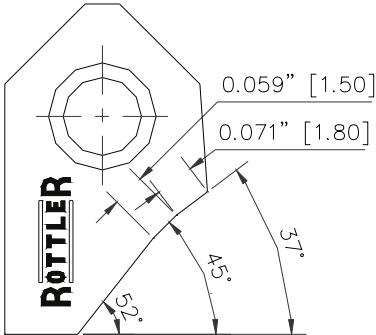
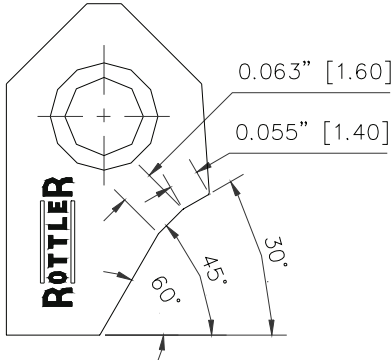
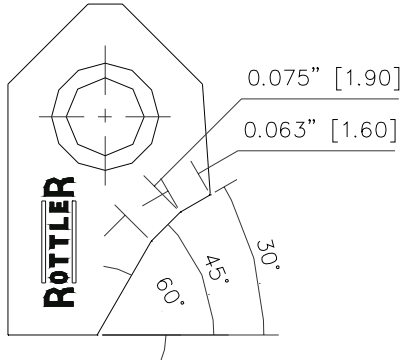
<p>RCA001 Carbide Seat Insert 30-45-60 / 1.2 -1.0mm</p> <p>RCA-001 (14 RC BIT KIT)</p> 	<p>RCA004 Carbide Seat Insert 30-45-60 / 1.6 -1.3mm</p> <p>RCA-004 (14 RC BIT KIT)</p> 	<p>RCA005 Carbide Seat Insert 37-45-52 / 2.0 -1.3mm</p> <p>RCA-005 (14 RC BIT KIT)</p> 
<p>RCA007 Carbide Seat Insert 37-45-52 / 1.8 -1.5mm</p> <p>RCA-007 (14 RC BIT KIT)</p> 	<p>RCA014 Carbide Seat Insert 30-45-60 / 1.4 -1.6mm</p> <p>RCA-014 (14 RC BIT KIT)</p> 	<p>RCA026 Carbide Seat Insert 30-45-60 / 1.6 -1.9mm</p> <p>RCA-026 (14 RC BIT KIT)</p> 

Suggested 30 Degree Seat Inserts

NOTE: Orders of 20+ of the same RCA insert receive 10% discount. Orders of 50+ of the same RCA insert receive 20% discount. Does not apply to mix-and-match orders.

<p>RCA301 Carbide Seat Insert 5-30-45 / 2.0 -1.3mm</p> <p>RCA-301 (14 RC BIT KIT)</p>	<p>RCA303 Carbide Seat Insert 15-30-45 / 1.4 -1.5mm</p> <p>RCA 303</p>	<p>RCA307 Carbide Seat Insert 15-30-45 / 1.8 -1.6mm</p> <p>RCA-307 (14 RC BIT KIT)</p>
<p>RCA348 Carbide Seat Insert 10-30-60 top width 2.2mm, seat width 1.8mm OFFSET Insert (For Detroit 53 Series Cylinder Head)</p> <p>RCA 348</p>		

Suggested 37.5 Degree Seat Inserts

NOTE: Orders of 20+ of the same RCA insert receive 10% discount. Orders of 50+ of the same RCA insert receive 20% discount. Does not apply to mix-and-match orders.

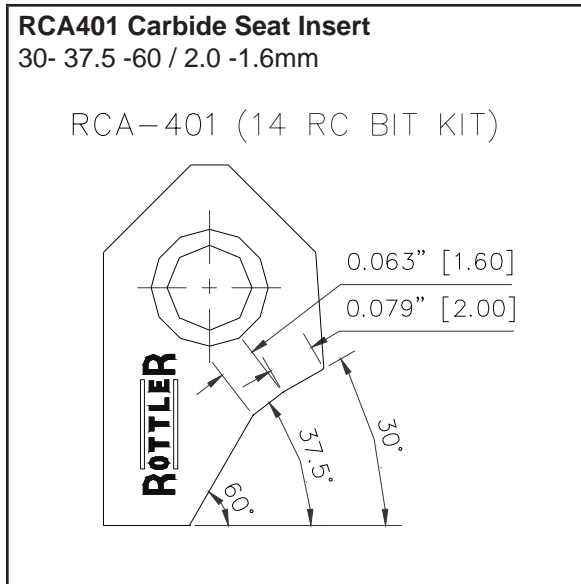

Suggested Straight Angle Seat Inserts

NOTE: Orders of 20+ of the same RCA insert receive 10% discount. Orders of 50+ of the same RCA insert receive 20% discount. Does not apply to mix-and-match orders.

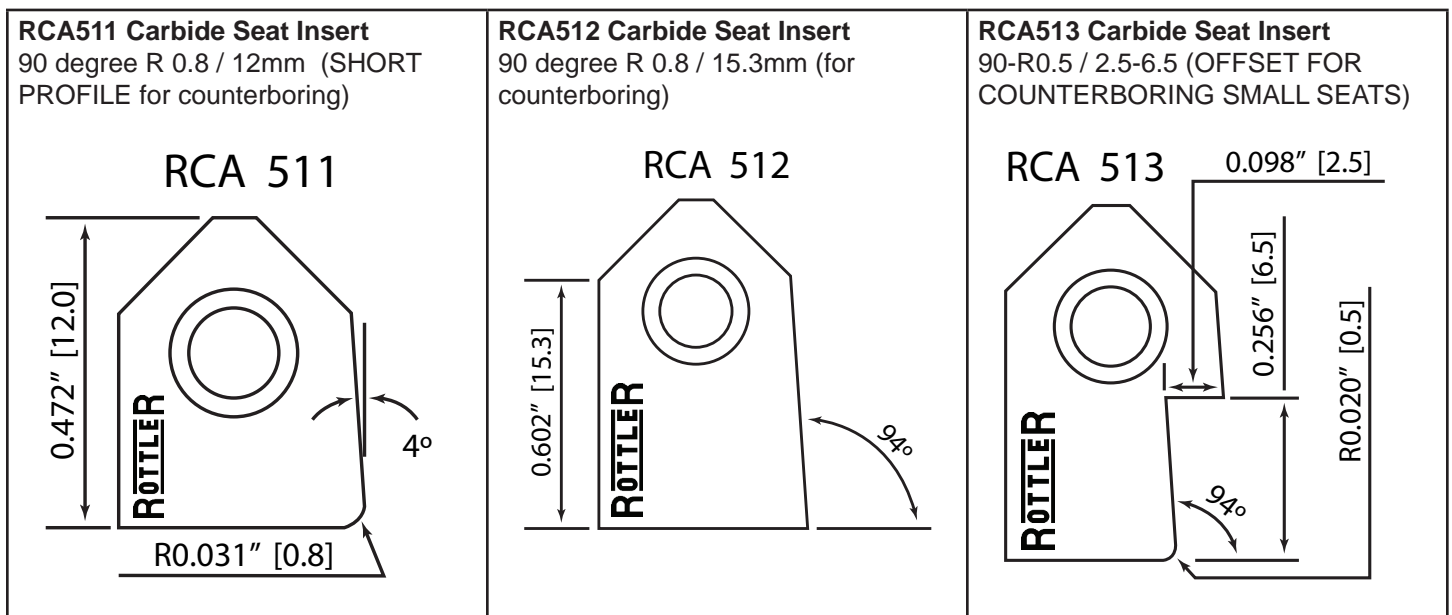

<p>RCA501 Carbide Seat Insert 20 degrees / 8.8mm</p> <p>RCA 501</p>	<p>RCA521 Carbide Seat Insert 25 degrees / 8.5mm</p> <p>RCA 521</p>	<p>RCA502 Carbide Seat Insert 30 degrees / 9.0mm</p> <p>RCA-502 (14 RC BIT KIT)</p>
<p>RCA503 Carbide Seat Insert 45 degrees / 8.9mm</p> <p>RCA 503</p>	<p>RCB506 Carbide Seat Insert 70 degrees / 16.8mm</p> <p>RCB 506</p>	

Suggested 45 Degree Seat Inserts for Multi-Valves Cylinder Heads

NOTE: Orders of 20+ of the same RCA insert receive 10% discount. Orders of 50+ of the same RCA insert receive 20% discount. Does not apply to mix-and-match orders.

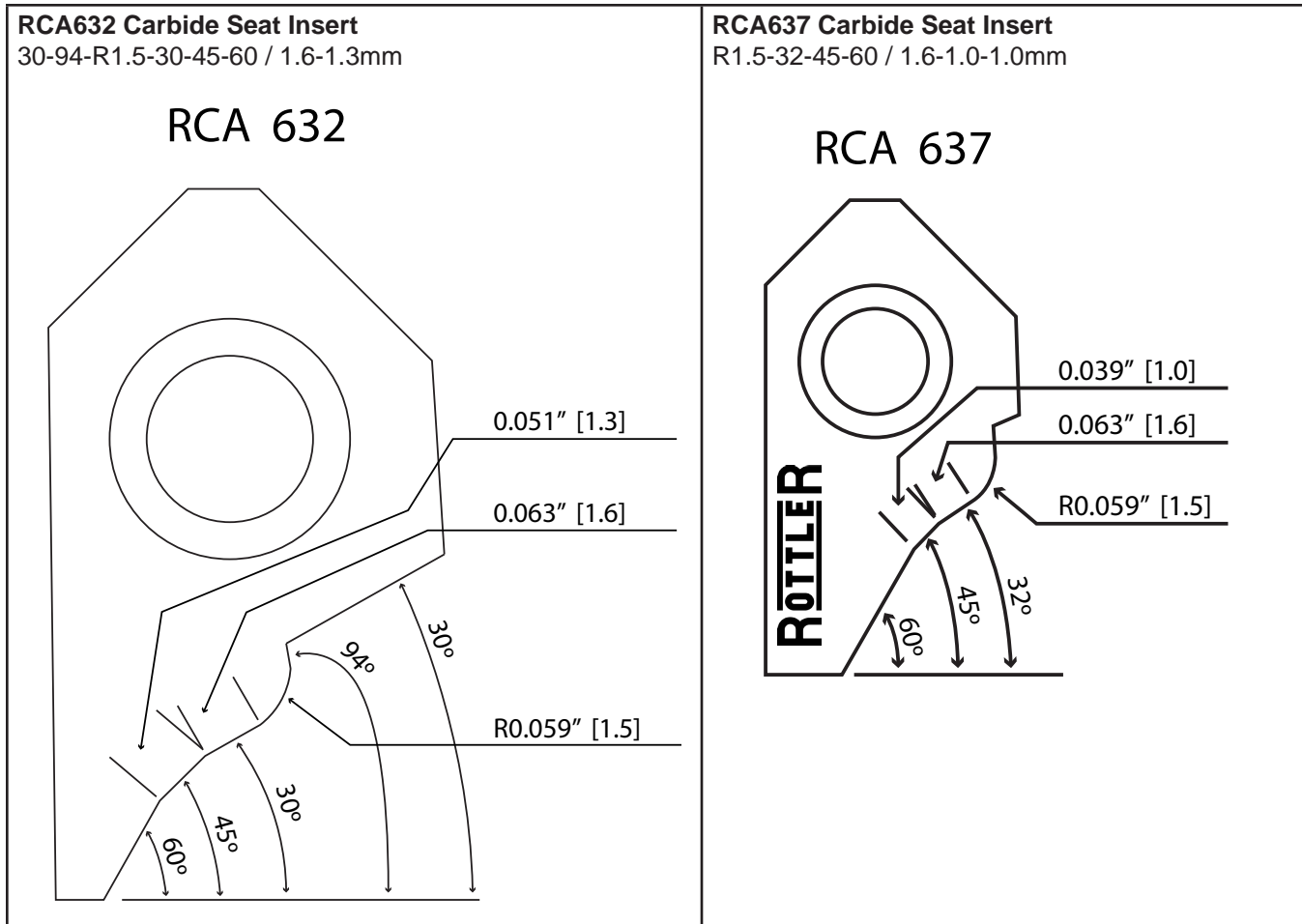

High Performance Inserts

NOTE: Orders of 20+ of the same RCA insert receive 10% discount. Orders of 50+ of the same RCA insert receive 20% discount. Does not apply to mix-and-match orders.

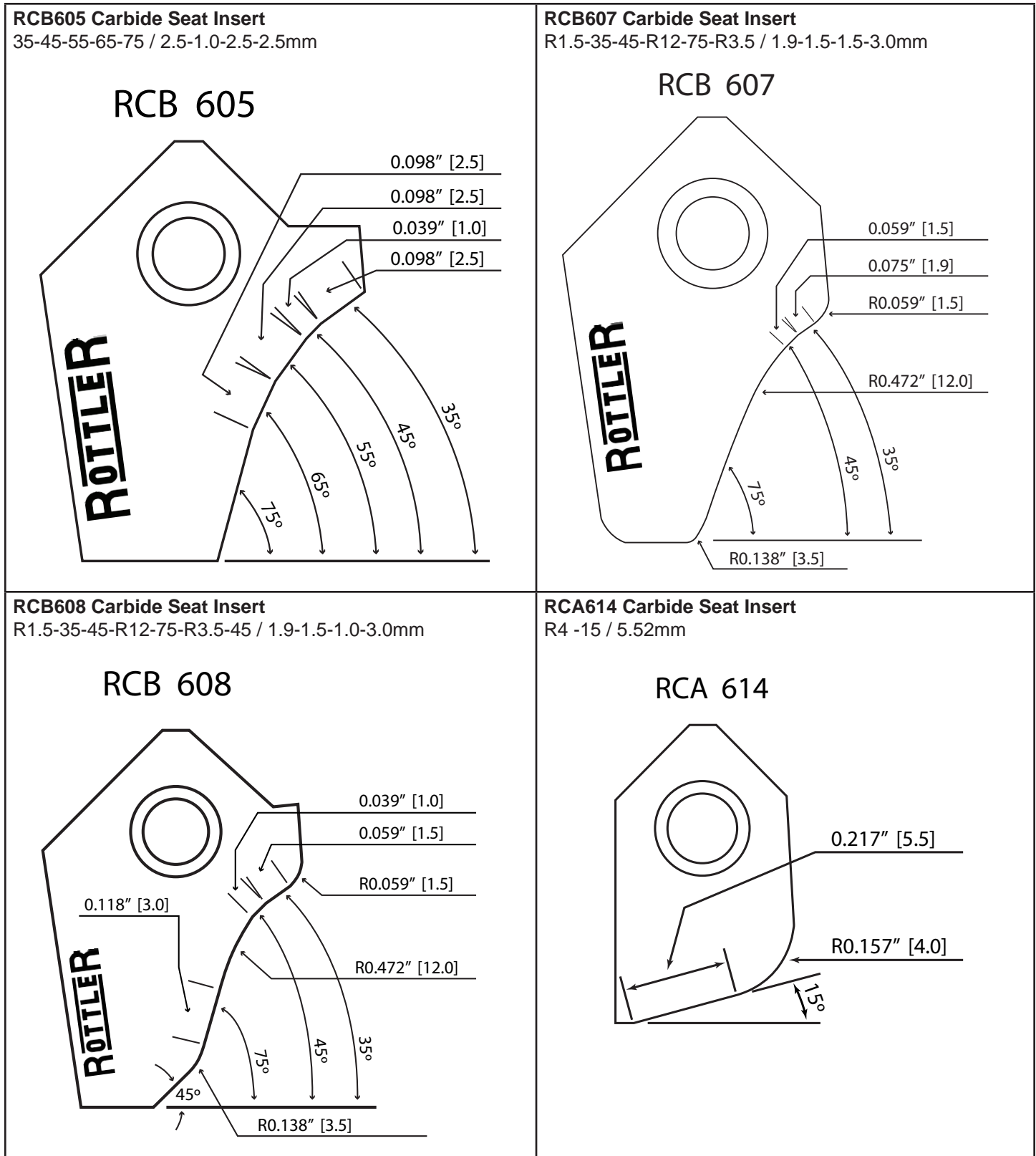

RCB620 Carbide Seat Insert
R7 -15

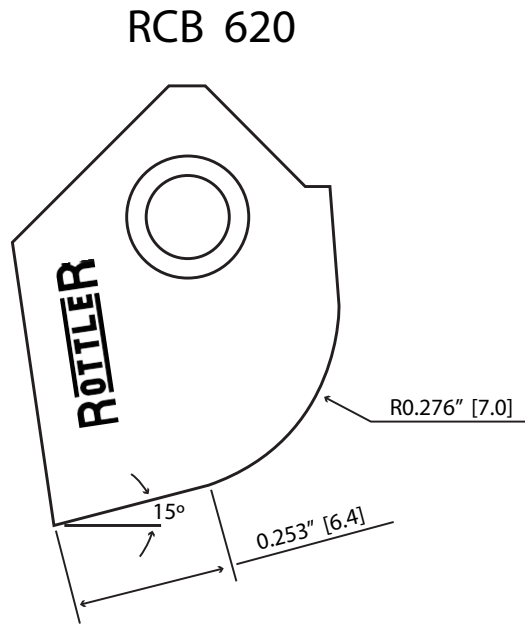

RCB621 Carbide Seat Insert
75 - R7 / 12.0mm

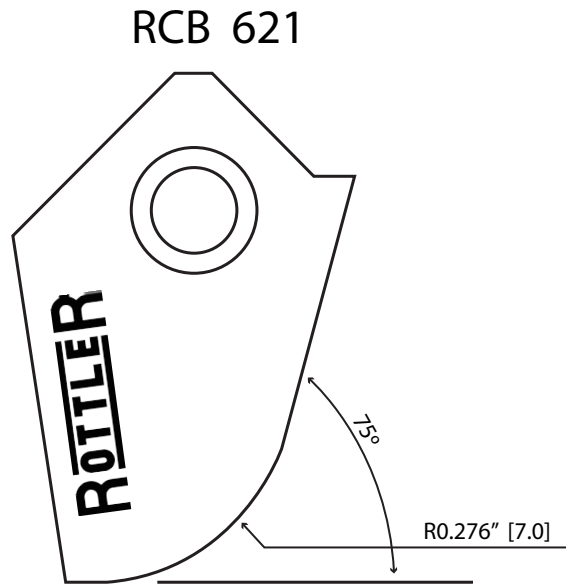

RCA623 Carbide Seat Insert
R0.8-30-45-60-R13-R1.5 / 1.0-1.0mm

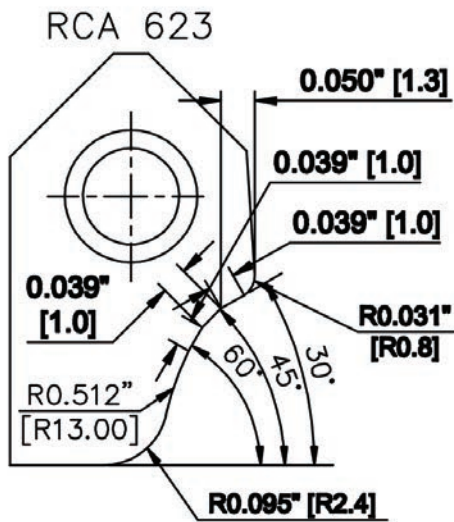

Harley Davidson Inserts

NOTE: Orders of 20+ of the same RCA insert receive 10% discount. Orders of 50+ of the same RCA insert receive 20% discount. Does not apply to mix-and-match orders.

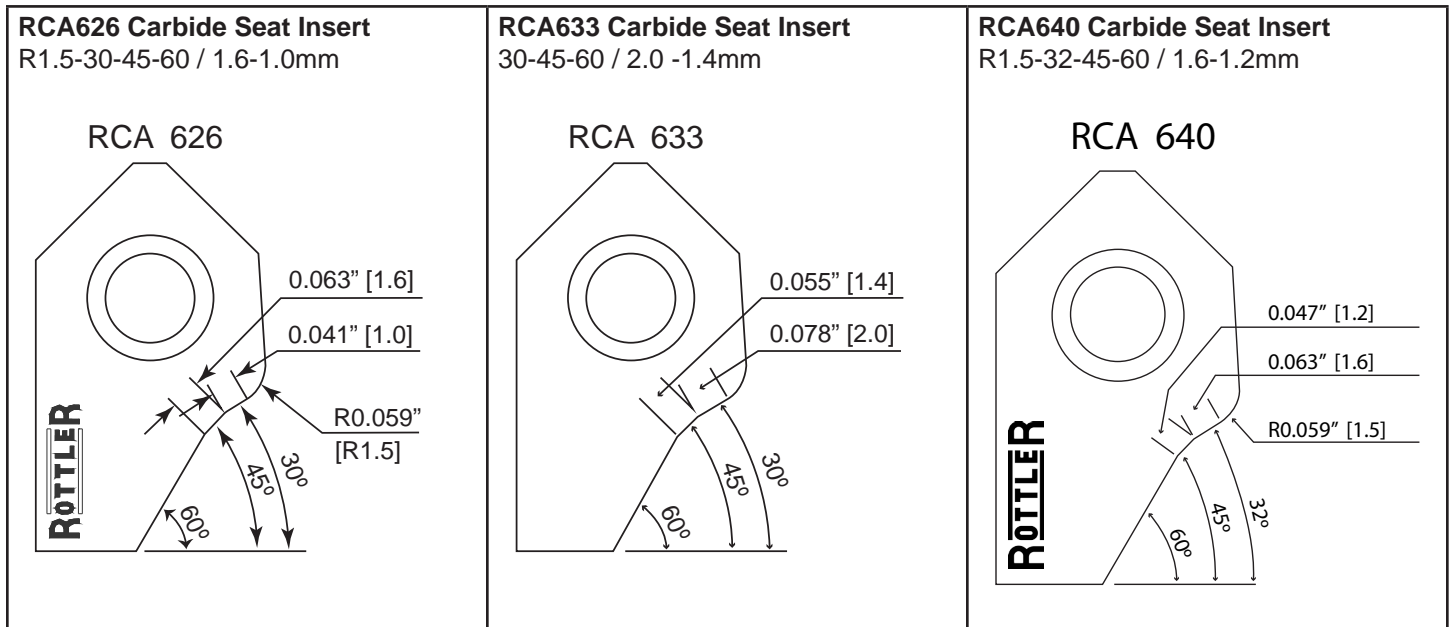

Counterboring and Straight Angles Inserts

NOTE: Orders of 20+ of the same RCA insert receive 10% discount. Orders of 50+ of the same RCA insert receive 20% discount. Does not apply to mix-and-match orders.

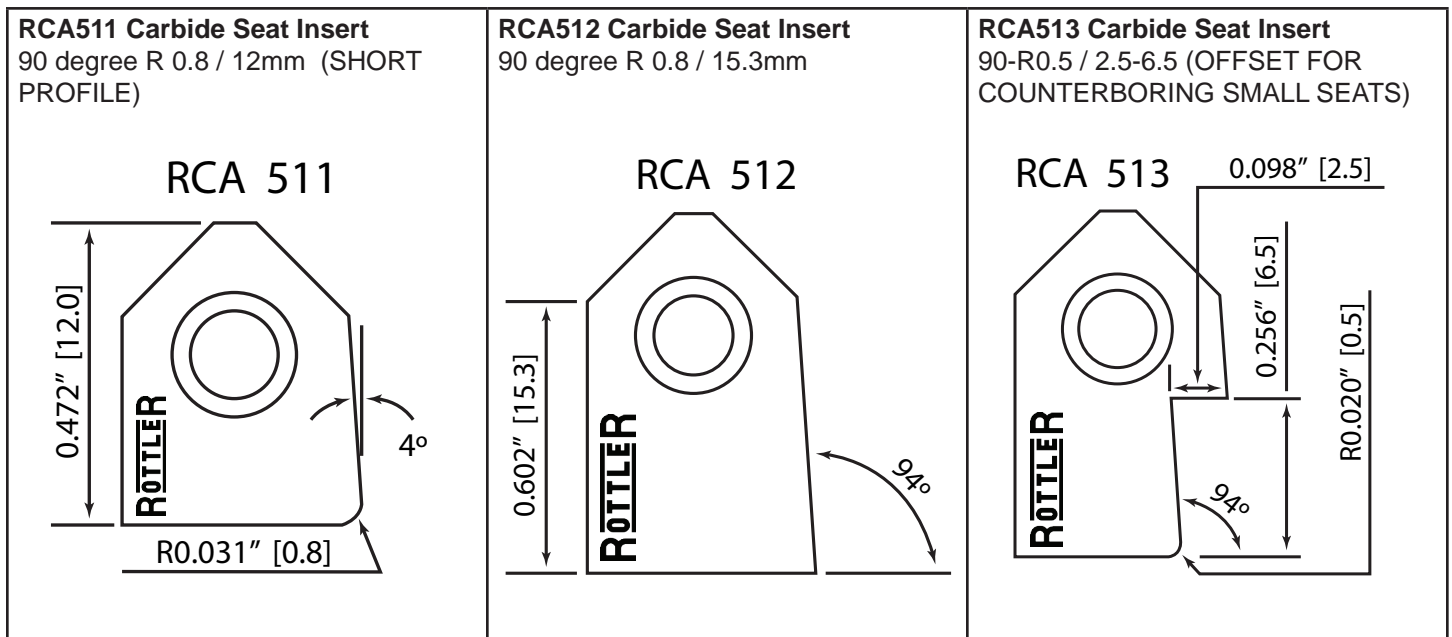

RT211 Insert, triangular

1/4" (6.35mm) 1/64" radius (1/4" triangle Insert holders only) FOR COUNTERBORING FOR INSERT HOLDERS THAT USE TRIANGLE INSERT STYLE.

**RT212 Insert, triangular**

1/4" (6.35mm) 1/32" radius (1/4" triangle Insert holders only) FOR COUNTERBORING FOR INSERT HOLDERS THAT USE TRIANGLE INSERT STYLE.



Rottler Special Profile Cutter Inserts Policy

Special Profile Cutter Inserts can be manufactured to your exact specifications and can include a combination of angles and radius blends. Special Profile Carbide Cutter Bits are generally considered to be "Customer Proprietary". These are uniquely numbered, exclusively for the ordering customer.

Contact Rottler Manufacturing for further information.

Available Carbide Pilots by Diameter and Length

NOTE: For Recommended Fixed Carbide, See SG Pilot Catalog.

UCPM-MINI	UNIPILOT Carbide Pilots with 6.00mm Shank Diameter / 5.700" long range from 3.50 - 7.00mm to be used on BH600-R1 Tool Holder and TH1999 Tip Holder)
UCP-5TO10STD	UNIPILOT Carbide Pilots UCP .375" (9.52mm) Shank Diameter / Total Length 7.500" Range from .196 - .394" (5.00 - 10.00mm)
UCP-10TO12STD	UNIPILOT Carbide Pilots UCP .375" (9.52mm) Shank Diameter / Total Length 7.500" Range from .390 - .470" (10.01 - 12.00 mm)
UCP-12TO14STD	UNIPILOT Carbide Pilots UCP .375" (9.52mm) Shank Diameter / Total Length 7.500" Range from .470 - .550" (12.01 - 14.00 mm)
UCP-14TO16STD	UNIPILOT Carbide Pilots UCP .375" (9.52mm) Shank Diameter / Total Length 7.500" Range from .551 - .630" (14.01 - 16.00mm)
UCP-UNDER10-9EL	UNIPILOT Carbide Pilot .375" (9.52mm) Shank Diameter Below .390" 10.00mm (9.00" extended length)
UCP-10TO14-9EL	UNIPILOT Carbide Pilot .375" (9.52mm) Shank Diameter (9.00" extended length) from 10.02 - 14.50mm
UCP-14TO16-9EL	UNIPILOT Carbide Pilot .375" (9.52mm) Shank Diameter (9.00" extended length) from 14.02 - 16.00mm
UCP-16TO19-9EL	UNIPILOT Carbide Pilot .375" (9.52mm) Shank Diameter (9.00" extended length) from 16.02 - 19.50mm
UCP-10TO14-12EL	UNIPILOT Carbide Pilot .375" (9.52mm) Shank Diameter (12.00" extended length) from 10.02 - 14.50mm
UCP-20MM	Any UNIPILOT Carbide Pilot 20.00mm Shank Diameter Up to 22.00mm pilot Diameter

Miscellaneous Tooling

CDR312 Combo Core drill / Reamer

.312" Pilot to bore for standard 1/2" OD valve guide insert with .375" diameter Shank, requires SAD375R1 spindle adapter or to be used with collet holder



CDR343 Combo Core drill / Reamer

.343" Pilot to bore for standard 1/2" OD valve guide insert with .375" diameter Shank, requires SAD375R1 spindle adapter or to be used with collet holder



CDR375 Combo Core drill / Reamer

.375" Pilot to bore for standard 1/2" OD valve guide insert with .375" diameter Shank, requires SAD375R1 spindle adapter or to be used with collet holder



VSD100-KIT Valve Seat Driver Kit

Includes Seat Driver Body (VSD101) 5 Dual seat Ring Adapters (VSD102 1 - 1.1/8", VSD103 1.1/4 - 1.3/8", VSD104 1.1/2 - 1.5/8", VSD105 1.3/4 - 1.7/8", VSD106 2 - 2.1/8"), 5 Solid Tapered Pilots STP0250, STP0275, STP0312, STP0343, STP0374



VGD-KIT Valve Guide Driver Kit

Includes .312" Valve Guide Driver, .343" Valve Guide Driver, .372" Valve Guide Driver and 7.0mm Valve Guide Driver (requires air hammer - not available from Rottler)



VGTC-KIT3 Valve Guide Top Cutter Kit

With 1/2" straight Shank. To be used with Collet holder or SAD500R1 Spindle Adapter. Kit includes 5/16", 11/32" & 3/8" pilot for guide top cutter



Fixed Double Insert Milling Heads

FMH Fixed Double Replaceable Insert Milling Heads - Bore diameter 1.25 - 2.50" (31.75 - 63.50mm) available in increments of 1/16" (.125") (Requires Milling Head driver) (specify size)

FMH1000R1 1.0000" Fixed Double Replaceable Insert Milling Head

With .562" Driver (Requires BD560 .562" ID Milling head Driver)



FMH10625R1 1.0625" Fixed Double Replaceable Insert Milling Head

With .562" Driver ID (Requires BD560 .562" ID Milling head Driver)



FMH11250R1 1.1250" Fixed Double Replaceable Insert Milling Head

With .562" Driver ID (Requires BD560 .562" ID Milling head Driver)



FMH11875R1 1.1875" Fixed Double Replaceable Insert Milling Head

With .562" Driver ID (Requires BD560 .562" ID Milling head Driver)



FMH13125R1 1.3125" Fixed Double Replaceable Insert Milling Head

With .562" Driver ID (Requires BD560 .562" ID Milling head Driver)



FMH13750R1 1.3750" Fixed Double Replaceable Insert Milling Head

With .562" Driver ID (Requires BD560 .562" ID Milling head Driver)



FMH14375R1 1.4375" Fixed Double Replaceable Insert Milling Head

With .562" Driver ID (Requires BD560 .562" ID Milling head Driver)

FMH15000R1 1.5000" Fixed Double Replaceable Insert Milling Head

With .562" Driver ID (Requires BD560 .562" ID Milling head Driver)

FMH15625R1 1.5625" Fixed Double Replaceable Insert Milling Head

With .562" Driver ID (Requires BD560 .562" ID Milling head Driver)

FMH16250R1 1.6250" Fixed Double Replaceable Insert Milling Head

With .562" Driver ID (Requires BD560 .562" ID Milling head Driver)

FMH16875R1 1.6875" Fixed Double Replaceable Insert Milling Head

With .562" Driver ID (Requires BD560 .562" ID Milling head Driver)

FMH17500R1 1.7500" Fixed Double Replaceable Insert Milling Head

With .562" Driver ID (Requires BD560 .562" ID Milling head Driver)



FMH18125R1 1.8125" Fixed Double Replaceable Insert Milling Head

With .562" Driver ID (Requires BD560 .562" ID Milling head Driver)



FMH18750R1 1.8750" Fixed Double Replaceable Insert Milling Head

With .562" Driver ID (Requires BD560 .562" ID Milling head Driver)







FMH20000R1 2.0000" Fixed Double Replaceable Insert Milling Head

With .562" Driver ID (Requires BD560 .562" ID. Ball Head Milling head Driver)

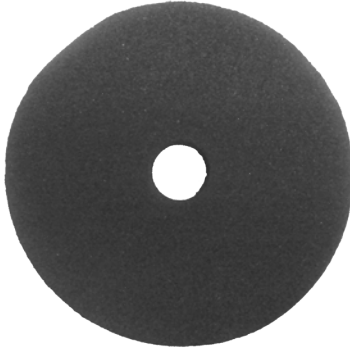
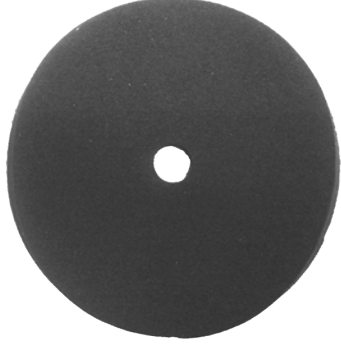
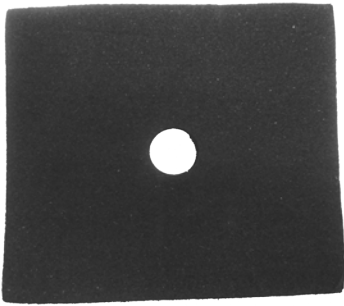
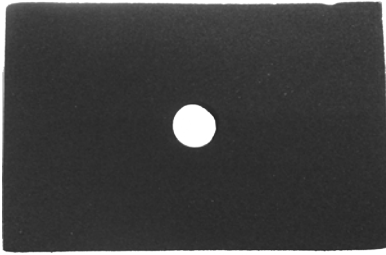
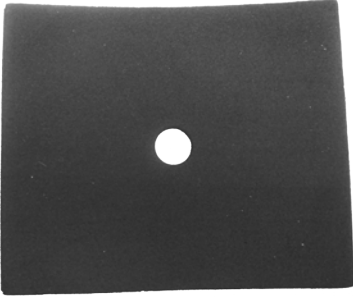

Consumable Parts for Seat and Guide Models

<p>SLEEVER1 Spindle Adapter Replacement Sleeve</p> 	<p>BSW002 Diamond Wheel Cutting Bit Sharpener replacement Wheel (3.000" Diameter OD by .375" ID)</p> 	<p>VT-FP1562 Replacement Foam Pad For Round Vacuum Pad 1.562" (39.675mm) diameter</p> 
<p>VT-FP1875 Replacement Foam Pad For Round Vacuum Pad 1.875" (47.625mm) diameter</p> 	<p>VT-FP2125 Replacement Foam Pad For Round Vacuum Pad 2.125" (53.975mm) diameter</p> 	<p>VT-FP3125 Replacement Foam Pad For Round Vacuum Pad 3.125" (79.375mm) diameter</p> 
<p>VT-FP25X22 Replacement Foam Pad For Square Vacuum Pad 2.500 X 2.250" (63.5 X 57.15mm) square</p> 	<p>VT-FP31X20 Replacement Foam Pad For Square Vacuum Pad 3.125 X 2.000" (79.375 X 50.8mm) square</p> 	<p>VT-FP33X27 Replacement Foam Pad For Square Vacuum Pad 3.375 X 2.750" (85.725 X 69.85mm) square</p> 

<p>PRW600PIN Replaceable Pin For PRW600 Pilot Removable wrench tool</p> 	<p>PRW375PIN Replaceable Pin For PRW375 Pilot Removable wrench tool</p> 	<p>PRW20PIN Replaceable Pin For PRW375 Pilot Removable wrench tool</p> 
<p>511-29-12E Torx Screw M2.5 X 0.45 (straight angle insert holders only)</p> 	<p>T7D T7 Torx Driver For 1/4" insert (straight angle insert holders only)</p> 	
<p>T8S T8 Torx Tip Holding Screws</p> 	<p>T15S T15 Torx Tip Holding Screws</p> 	<p>S1032-250 BH375R1 and BH600R1 Tip Holder Locking Screw 10/32" X 1/4" (requires 2)</p> 
<p>S250-28-250 BH375WR1 Tip Holder Locking Screw 1/4"-28" X 1/4" (requires 2)</p> 	<p>S1032-437 TH1999 Adjusting Screw (10/32 X 7/16")</p> 	<p>S1032-375 TH2000 Adjusting Screw (10/32 X 3/8")</p> 
<p>S1032-500 TH2001 Adjusting Screw (10/32 X 1/2")</p> 	<p>S1032-625 TH2002 Adjusting Screw (10/3" X 5/8")</p> 	<p>S500-1600 TH2003 Adjusting Screw (6.00 X 16mm)</p> 
<p>S600-2015 TH2004 Adjusting Screw (6.00 X 20.15mm)</p> 	<p>ICC003 Insert, Indexable Carbide For Fixed milling heads - large size - for 1.562" and larger cutters</p> 	<p>ICC002 Insert, Indexable Carbide For Fixed milling heads - small size - for 1.250 - 1.500" cutters</p> 